

The logo for Bystronic, featuring the word "Bystronic" in a bold, white, sans-serif font. The letter "y" is stylized with a grid of white dots forming its shape. The logo is set against a solid black background.











**Bystronic**

**Best choice.**

**Bystronic Tools**

Laser | Bending | Waterjet  
[bystronic.com](http://bystronic.com)

## Overview about the icons used in this catalogue

	Material / Hardness
	max. permitted load
	method of tool loading
	nature of load
	max. box depth
	weight
	availability / delivery time
	clamping type
	drawing number (BOSbase reference)
	reversible tool
	bottom tool support

## Content

The Bystronic “bending world” ..... 4

### Air bending (Xpert / Xact)

basis of calculation ..... 14

upper tools and bottom tools Xpert ..... 20

upper tools and bottom tools Xact ..... 110

### 3-point-bending (Hämmerle 3P)

basis of calculation ..... 160

upper tools and bottom tools ..... 168

## Workshop

### Taking bending into design

Small bending radii?  
Short flange length?  
Too much welding, cleaning and flattening?  
Bending marks?



What are the topics?

- Basics
- Software presentations
- Machine presentations
- Industrial design expert talks
- Case studies
- Your questions

You can obtain date and further information from our consulting engineers, all contact dates you can be found on the last page.

Further information can be obtained at: [www.bystronic.com](http://www.bystronic.com)

## Bending seminar

### Bending of high tensile strength materials

Material costs are too high?  
Wear and tear resistance relevant?  
Challenge light construction?  
Steel broken yet?



What are the topics?

- Basics
- Experts talks of steel producers
- How the software can help
- Bend case studies
- Specialist talks

You can obtain data and further information from our consulting engineers, all contact data can be found on the last page.

Further information can be obtained at: [www.bystronic.com](http://www.bystronic.com)

## Special applications

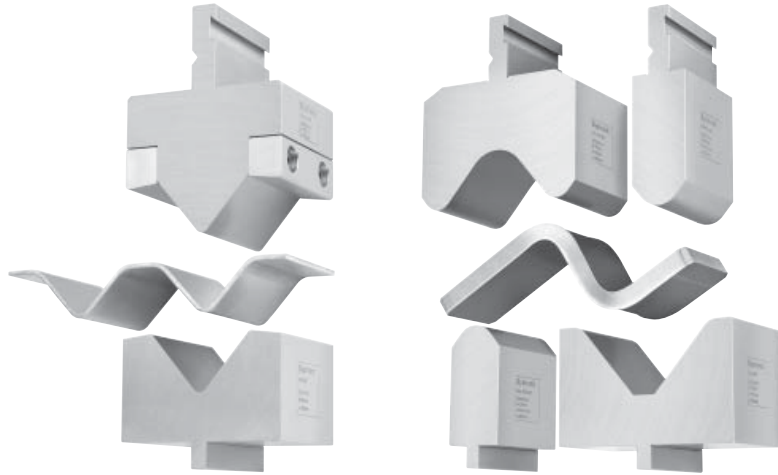

Special tools are also part of the Bystronic tooling range.

Our tooling specialist will help you to solve your forming problems, all contact information are located at the end of the catalog.

Visit our shop in the Internet under: [www.bystronic.com](http://www.bystronic.com)

## Special applications

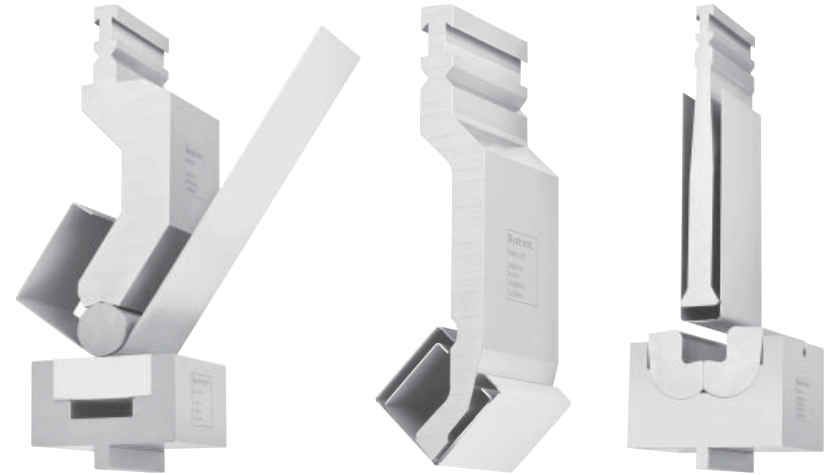

## Bystronic bending methods

### Air bending

For material thicknesses  
up to 50 mm mild steel

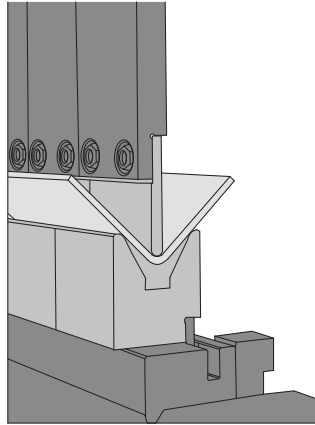

### Coining

For material thicknesses  
up to 3 mm mild steel

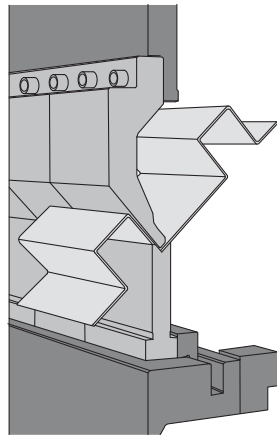

## Bystronic bending methods

### 3-point-bending

Up to 12 mm mild steel

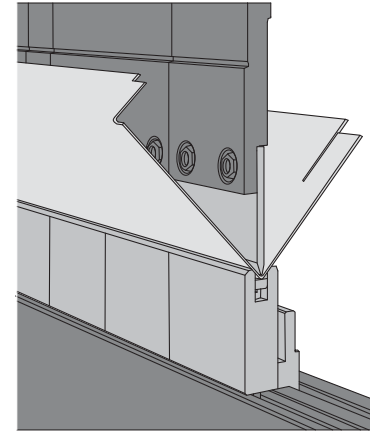

## Bystronic bending methods

### Principle of air bending

With the air bending method the bending angle is determined by the depth of penetration of the upper tool into the lower die. To that effect and amongst other factors the bending accuracy is mainly dependant upon the positional accuracy of the upper beam. Under load the material is stressed from A to C. After removal of the load the portions AD and EC spring back into thier original positions. In the case of ari bending without bottoming the vees of the bottom tool and the angle of the top tool must be smaller than  $90^\circ$ .

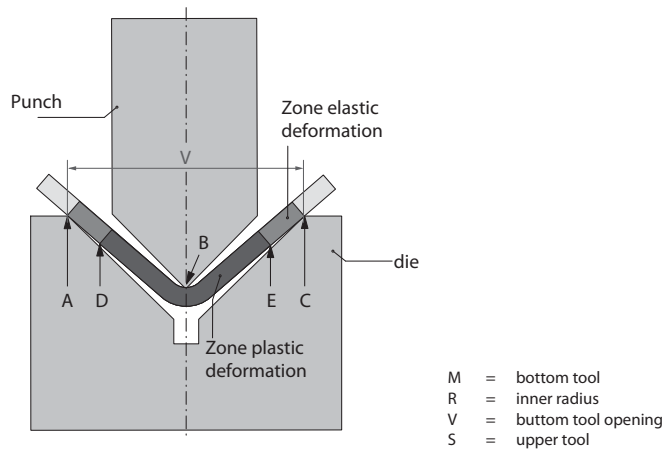

## Bystronic bending methods

### Principle of bottoming

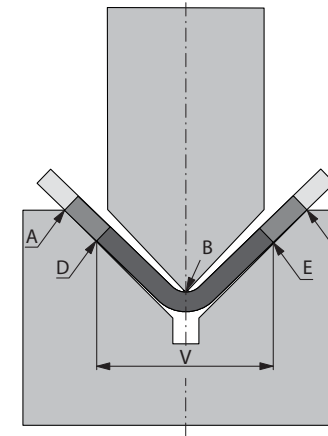

As soon as the areas AD and CE touch the sides of the vee in air bending with bottoming they will spring back into thier original position until the positions of contact have to move to D and E.

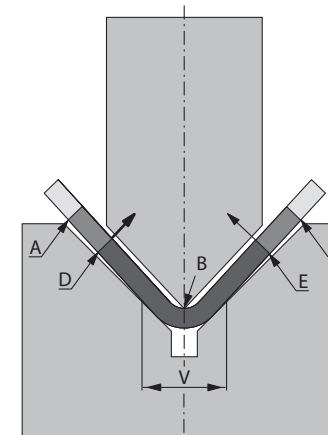

A still further penetration of the top tool will result in a disengagement of the points D and E from the lower die as the points of contact start to move in the overbending is larger than the spring back of the portion located underneath the points of contact the angle of the section after removal of the load will be smaller than the angle of the vee..

## Bystronic bending methods

### Principle of coining

A further penetration of the top tool will result in a reopening of the section D and E until the top tool completely bottoms out on to the material. (start of the coining process).

The variation of the forces versus the travel of the top tool is a function of the material. The bottoming or coining process corresponds to a continuous reduction of the die opening (V). The smaller the width of the vee during coining results in a corresponding reduction of spring back in comparison to airbending. The bending forces required are 4 to 8 times greater than those required for air bending.

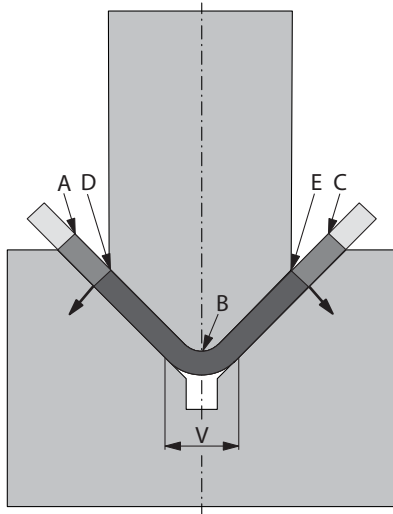

## Bystronic bending methods

### Principle of 3-pont-bending

For the 3-point-bending the bottom tool groove depth (H) is accomplished with an accuracy of 1/1000 mm by means of a precise wedge system. With given sheet metal quality, sheet metal characteristics and plate thickness and taking resilience of the part into account, the bend angle to be produced is governed predictably and accurately by bottom tool depth (F). The top tool segments positioned along the bending line thereby adapts to the bending line of the bottom tools. The hydraulic cushion compensates for machine and material related factors.

The 3-point-bending process is something in between air bending and coining and delivers highest accuracy and flexibility. It opens new possibilities in designing and manufacturing of parts.

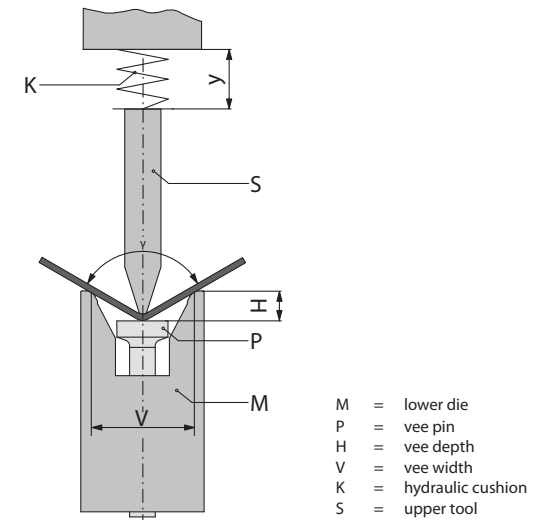

- M = lower die
- P = vee pin
- H = vee depth
- V = vee width
- K = hydraulic cushion
- S = upper tool

# Calculation basics for air bending

### Capacity chart for air bending

The given data has been calculated based upon bending material with a tensile strength of  $R_m = 420 \text{ N/mm}^2$  over a length of 1 m.

V	6	8	10	12	16	18	20	24	32	40	50	60	80
R	1	1.2	1.6	2	2.5	2.8	3	3.5	5	6	8	9.5	12
t	Bending force force in kN/1 m bending length												
a	Minimum flange length in mm												
0.5	25												
	4.3												
0.8	70	48											
	4.6	5.7											
1	115	80	60										
	5	6	7										
1.2		120	90	70									
		6	7.5	8.5									
1.5			150	120									
			8	9									
2.0			235	160	135	120	95						
			10	12	13	14.5	17						
2.5				265	225	200	155	110					
				12.5	14	15.5	17.5	23					
3.0						300	240	165	125				
						15.5	17.5	23.5	28				
4.0								315	235	180			
								25	29	35			
5.0								535	430	310	250		
								26	31	35.5	43		
6.0									610	450	360		
									32	36	44		
8.0										880	690	470	
										40	46	57	
10												800	
												60	
12													1200
													62
16													
18													
20													

Sheets with mill scale will increase the bending force by a factor of 1,05-1,1

# Calculation basics for air bending

### Capacity chart for air bending

100	120	130	140	150	160	180	190	200	230	260	290	320
15.5	19	21	23	24.5	26	28	30	32	36	40	45	50
t	Bending force force in kN/1 m bending length											
a	Minimum flange length in mm											
360												
71												
600	470	430	390									
71	85	92	100									
900	710	650	580	550	500							
73	86	92	100	105	115							
	1400	1250	1150	1050	950	810	800	710	600			
	90	98	105	110	115	130	135	140	160			
			1480	1350	1250	1100	1000	950	800	700	600	
			105	110	120	130	135	140	160	180	205	
						1400	1300	1200	1000	900	850	700
						135	140	145	165	180	205	225

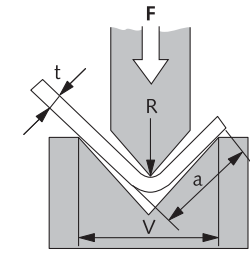

The internal radius  $R$  corresponds to approximately 16% of the die opening  $V$ .



## Calculation basics for air bending

### Calculation formulas

Recommended bottom tool opening V for air bending

Material thickness	t	0.5–2.5 mm	3–8 mm	9–10 mm	> 12 mm
Bottom tool opening	V	6 × t	8 × t	10 × t	12 × t

Bending force for

Aluminium	$R_m = 300 \text{ N/mm}^2$	$F = F(\text{table}) \times 0.65$
Mild steel	$R_m = 420 \text{ N/mm}^2$	$F = F(\text{table})$
Stainless steel	$R_m = 700 \text{ N/mm}^2$	$F = F(\text{table}) \times 1.6$

Determination of the bending force for air bending (reference data)

$$F = \frac{R_m \times t^2}{V} \times \left(1 + \frac{4 \times t}{V}\right)$$

Conversion:  $R_m = \text{tensile strenght in N/mm}^2$

10 N  $\cong$  1 kg

10 kN  $\cong$  1 t

### Conversion for minimal internal radii R

thickness t	1	2	3	4	5	6	8	10	12	16	18	20
min. R	1	2	3	5	6	8	12	16	20	28	36	40

## Calculation basics for air bending

### Tensile strength

Steel	Tensile strength
GG-20	$R_m = 200 \text{ N/mm}^2$
GGG-40	$R_m = 400 \text{ N/mm}^2$
G-X 6 CrNi 18 9	$R_m = 450 \text{ N/mm}^2$
S 355 MC	$R_m = 550 \text{ N/mm}^2$
S 420 MC	$R_m = 550 \text{ N/mm}^2$
S 460 MC	$R_m = 620 \text{ N/mm}^2$
GS-60	$R_m = 650 \text{ N/mm}^2$
S 500 MC	$R_m = 700 \text{ N/mm}^2$
S 550 MC	$R_m = 760 \text{ N/mm}^2$
S 600 MC	$R_m = 820 \text{ N/mm}^2$
S 650 MC	$R_m = 880 \text{ N/mm}^2$
S 700 MC	$R_m = 950 \text{ N/mm}^2$
42 CrMo 4	$R_m = 1000 \text{ N/mm}^2$

Please ask your responsible Consultant for bending high strength materials.

## Notes

## Calculation basis for air bending

### Working space determination

Tonnage	Day-light	Day-light	Stroke	Punch height	Working height	Clamping height	Box depth	Die height	Table height	Free space	Width upper beam
	DL mm	DLW mm	SH mm	PH mm	WH mm	CH mm	BH mm	DH mm	TH mm	FS mm	UB mm
		Modufix				**				*	
		Wila				**					
60t	500	420	215	155	116	39	53.2	55	145	184	80
				175	115	60	52.5	55	145	185	80
				250	190	60	105	55	145	110	80
100t	500	420	215	155	116	39	56.7	55	145	184	70
				175	115	60	56	55	145	185	70
				250	190	60	108.5	55	145	110	70
150t	500	420	215	155	116	39	56.7	55	145	184	70
				175	115	60	56	55	145	185	70
				250	190	60	108.5	55	145	110	70
200t	500	420	215	155	116	39	53.2	55	145	184	80
				175	115	60	52.5	55	145	185	80
				250	190	60	105	55	145	110	80
250t	550	470	265	155	116	39	53.2	55	145	234	80
				175	115	60	52.5	55	145	235	80
				250	190	60	105	55	145	160	80
320t	550	470	265	155	116	39	46.2	55	145	234	100
				175	115	60	54.5	55	145	235	100
				250	190	60	98	55	145	160	100

\* Not valid for WILA Modufix,

\*\* Clamping height S/R/Wila = 39, RF/RF-A = 60

Calculation formula

for box depth.  $BH = (PH - CH - UB : 2) \times 0,7$

To calculate the remaining working day light for given machine and tool combination.  $FS = DL - TH - DH - WH$

## Calculation basics for air bending

### Working space determination

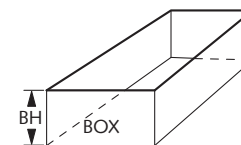
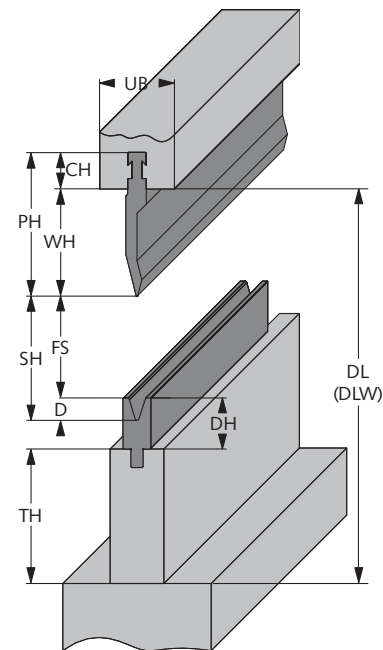

# Upper tools Xpert



## Upper tools Xpert

### Recommendation starterkit Xpert 60 - 320

Bend lengtht	Part number	Designation	Pieces	Unit
2050 mm	65206.0005.5007	Punch P5 RF-A/30° L=515	4	pieces
	65206.0005.0003	Punch P5 RF-A/30° L=1000 sect. FSC	1	piece
	64201.0012.3009	Die V12/30° L=1030	2	pieces
	64201.0012.0002	Die V12/30° L=1000 sect.FSC	1	piece
2550 mm	65206.0005.5007	Punch P5 RF-A/30° L=515	5	pieces
	65206.0005.0003	Punch P5 RF-A/30° L=1000 sect. FSC	1	piece
	64201.0012.3009	Die V12/30° L=1030	2	pieces
	64201.0012.0002	Die V12/30° L=1000 sect.FSC	1	piece
3100 mm	65206.0005.5007	Punch P5 RF-A/30° L=515	6	pieces
	65206.0005.0003	Punch P5 RF-A/30° L=1000 sect. FSC	1	piece
	64201.0012.3009	Die V12/30° L=1030	3	pieces
	64201.0012.0002	Die V12/30° L=1000 sect.FSC	1	piece
4100 mm	65206.0005.5007	Punch P5 RF-A/30° L=515	8	pieces
	65206.0005.0003	Punch P5 RF-A/30° L=1000 sect. FSC	1	piece
	64201.0012.3009	Die V12/30° L=1030	4	pieces
	64201.0012.0002	Die V12/30° L=1000 sect.FSC	1	piece

## Description upper tools

### Clamping R

R mechanical  
(Standard Xpert 60 – 320)

R hydraulic  
(Optional Xpert 60 - 320)

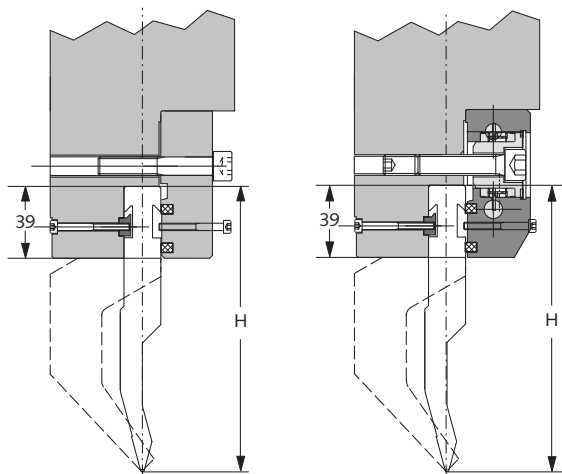

- Head support  $\leq 1600$  kN/m shoulder supp.  $> 1600$  kN/m
- Sideways and vertical insertion possible
- Head and shoulder supported possible
- Mechanical and hydraulic
- Tools are reversible

Because of the height of the clamping area, R type is suitable for light - medium duty clamping applications.

## Description upper tools

### Clamping RF

RF mechanical  
(Standard Xpert 250 – 1000)

RF hydraulic  
(Optional Xpert 250 - 1000)

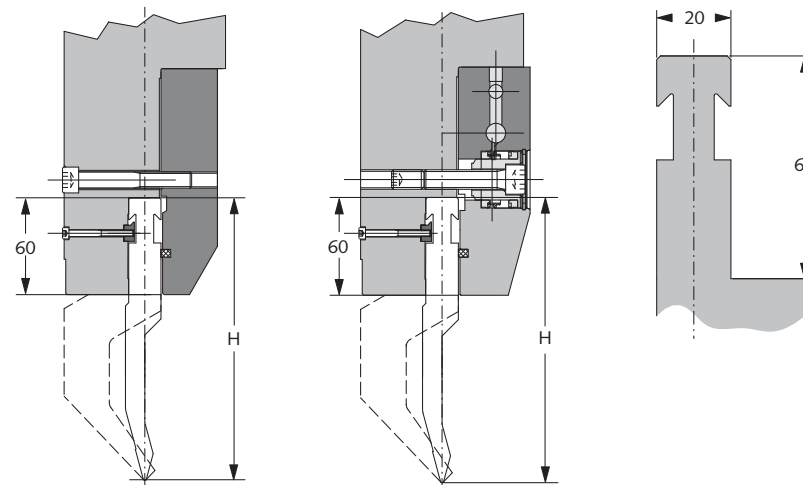

- Head support  $\leq 1600$  kN/m shoulder supp.  $> 1600$  kN/m
- Sideways and vertical insertion possible
- Head and shoulder supported possible
- Mechanical and hydraulic
- Tools are reversible

Because of the height the RF type clamping is suitable for medium to high applications.

## Description upper tools

### Clamping RF-A

RF-A hydraulic

(Optional Xpert 60 - 320 and Xpert 250 - 1000)

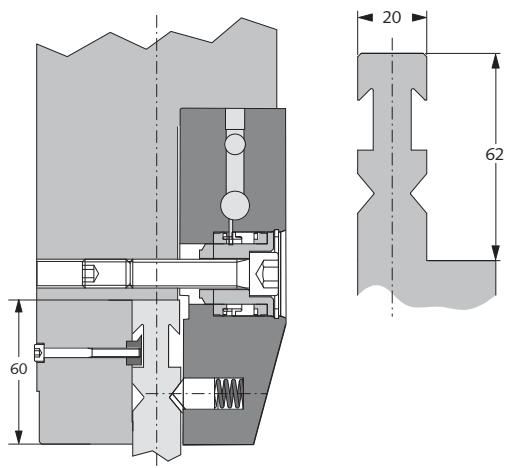

The automatic centering of the RF-A hydraulic clamping system helps to shorten the setup time by up to 20%. This combined with the large clamping area makes it a very popular option among users of both Xpert 60-320 machines and also the large Xpert machines 250 - 1000

Head support  $\leq 1600$  kN/m shoulder supp.  $> 1600$  kN/m

Sideways and vertical insertion possible

Head and shoulder supported possible

Hydraulic

Tools are reversible

Maximum tool weight  
50 kg / m

## Description upper tools

### Clamping MAMMUT Ergo

MAMMUT Ergo hydraulic

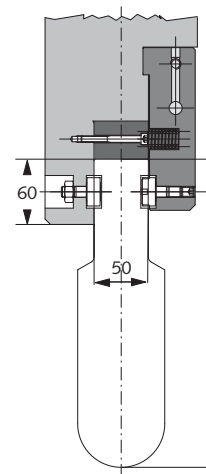

Head supported  $\leq 3200$  kN/m shoulder su.  $> 3200$  kN/m

Sideways insertion

Head and shoulder supported possible

Hydraulic

Tools are reversible

The MAMMUT Ergo is specially designed for high loads and the use of heavy tools. The MAMMUT Ergo is designed with casters for easy and quick tooling setup.

### Description upper tools

#### Upper tool segments for R / RF / RF-A

##### Horns R / RF / RF-A

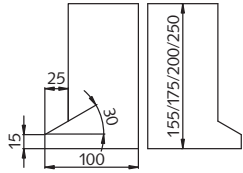

##### FSC / 1000 mm

(10 + 15 + 20 + 30 + 50 + 100 + 200 + 275 + 300)

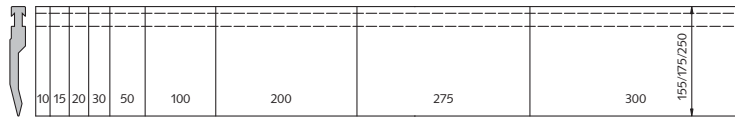

##### FSL / 1100 mm

(10 + 15 + 20 + 30 + 50 + 100 + 200 + 375 + 300)

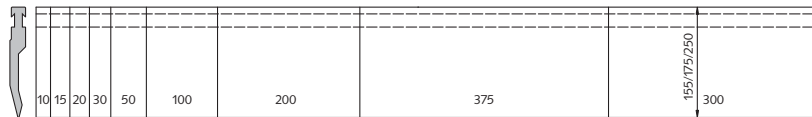

### Notes

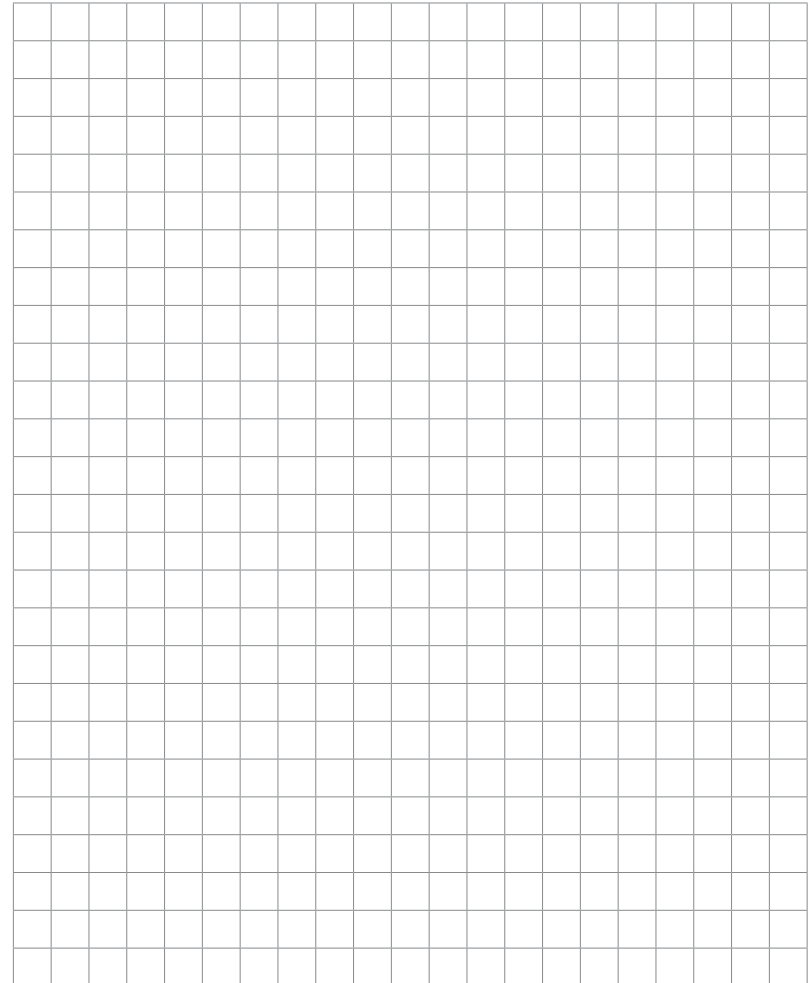

## P2 RF-A H175



[R] Radius (mm) 1

Nose angle 85°

[H] Height (mm) 175

 42 CrMo 4

 58 - 62 HRC

  $F_{max} = 1300 \text{ kN/m}$

 Operator side

 Head supported

 24.1 kg/m

 Hydraulic clamping

 45.5 mm

 Ex stock / 24 h

 BOS No. BY1C003

Standard length	Part number
515 mm	65206.0002.5001
1030 mm	65206.0002.3004
1000 mm sect. FSC	65206.0002.0003
1100 mm sect. FSL	65206.0002.1001
Horn set LH + RH	65206.0002.7001

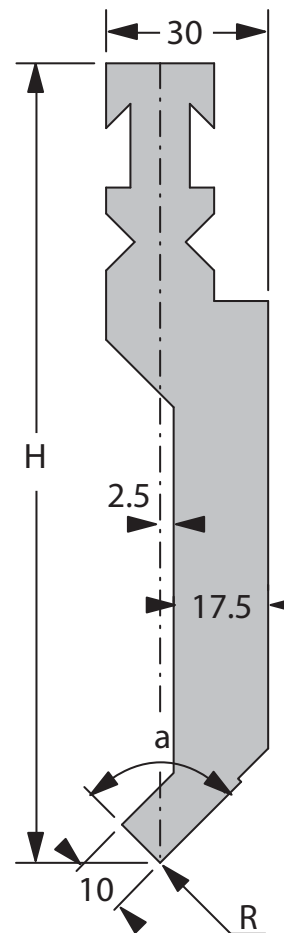

P2 RF-A / 85°  
 $F = 1300 \text{ kN/m}$   
 $R = 1 \text{ mm}$   
 $H = 175 \text{ mm}$

## P2 RF-A H250



[R] Radius (mm) 1

Nose angle 85°

[H] Height (mm) 250

 42 CrMo 4

 58 - 62 HRC

  $F_{max} = 1000 \text{ kN/m}$

 Operator side

 Head supported

 34.4 kg/m

 Hydraulic clamping

 98.0 mm

 Ex stock / 24 h

 BOS No. BY1C004

Standard length	Part number
515 mm	65206.0002.5005
1030 mm	65206.0002.3009
1000 mm sect. FSC	65206.0002.0001
1100 mm sect. FSL	65206.0002.1004
Horn set LH + RH	65206.0002.7003

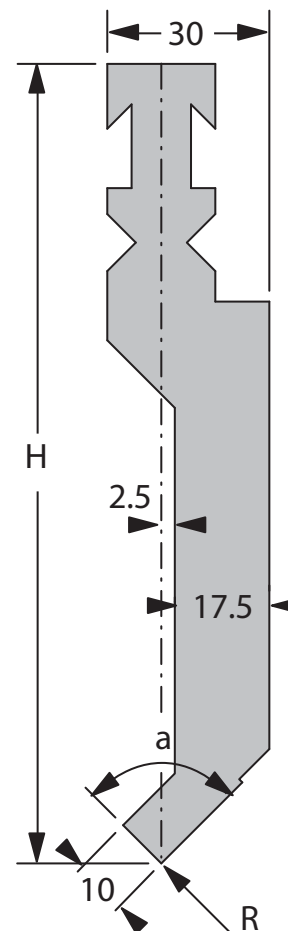

P2 RF-A / 85°  
 $F = 1000 \text{ kN/m}$   
 $R = 1 \text{ mm}$   
 $H = 250 \text{ mm}$



## P3 RF-A H175



[R] Radius (mm) 1

Nose angle 85°

[H] Height (mm) 175

 42 CrMo 4

 58 - 62 HRC

  $F_{max} = 1300 \text{ kN/m}$

 Operator side

 Head supported

 24.5 kg/m

 Hydraulic clamping

 45.5 mm

 Ex stock / 24 h

 BOS No. IB00545

Standard length	Part number
515 mm	65206.0003.5005
1030 mm	65206.0003.3001
1000 mm sect. FSC	65206.0003.0002
1100 mm sect. FSL	65206.0003.1005
Horn set LH + RH	65206.0003.7006

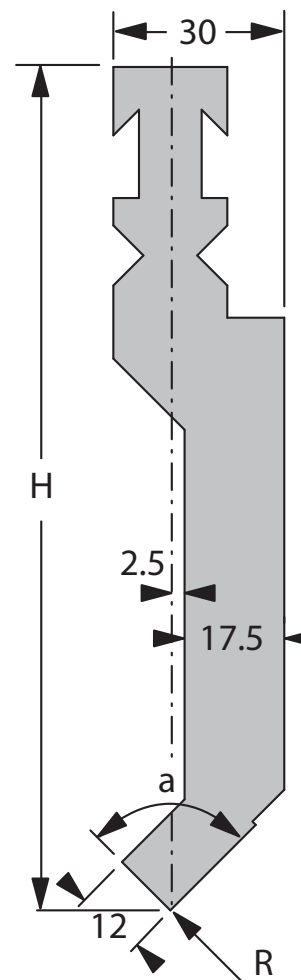

P3 RF-A / 85°  
 $F = 1300 \text{ kN/m}$   
 $R = 1 \text{ mm}$   
 $H = 175 \text{ mm}$

## P3 RF-A H250



[R] Radius (mm) 1

Nose angle 85°

[H] Height (mm) 250

 42 CrMo 4

 58 - 62 HRC

  $F_{max} = 1400 \text{ kN/m}$

 Operator side

 Head supported

 34.8 kg/m

 Hydraulic clamping

 98.0 mm

 Ex stock / 24 h

 BOS No. BY10176

Standard length	Part number
515 mm	65206.0003.5003
1030 mm	65206.0003.3004
1000 mm sect. FSC	65206.0003.0009
1100 mm sect. FSL	65206.0003.1002
Horn set LH + RH	65206.0003.7002

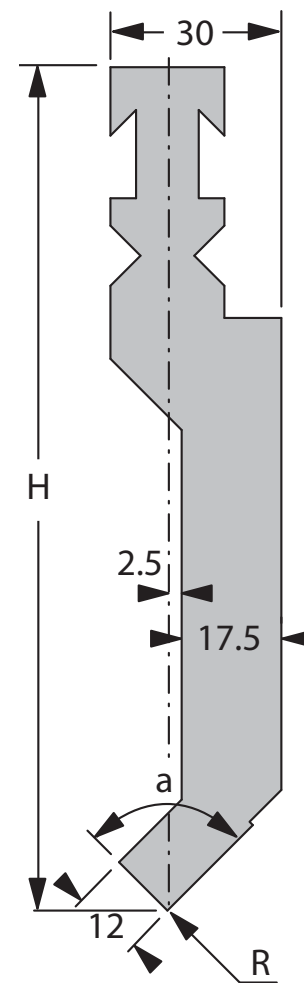

P3 RF-A / 85°  
 $F = 1400 \text{ kN/m}$   
 $R = 1 \text{ mm}$   
 $H = 250 \text{ mm}$

## P4 RF-A H175

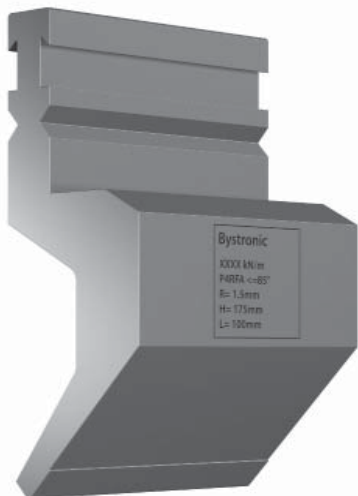

[R] Radius (mm) 1.5

Nose angle 85°

[H] Height (mm) 175

 42 CrMo 4

 58 - 62 HRC

  $F_{max} = 900 \text{ kN/m}$

 Operator side

 Head supported

 31.8 kg/m

 Hydraulic clamping

 45.5 mm

 Ex stock / 24 h

 BOS No. BY1C011A

Standard length	Part number
515 mm	65206.0004.5005
1030 mm	65206.0004.3005
1000 mm sect. FSC	65206.0004.0003
1100 mm sect. FSL	65206.0004.1002
Horn set LH + RH	65206.0004.7002

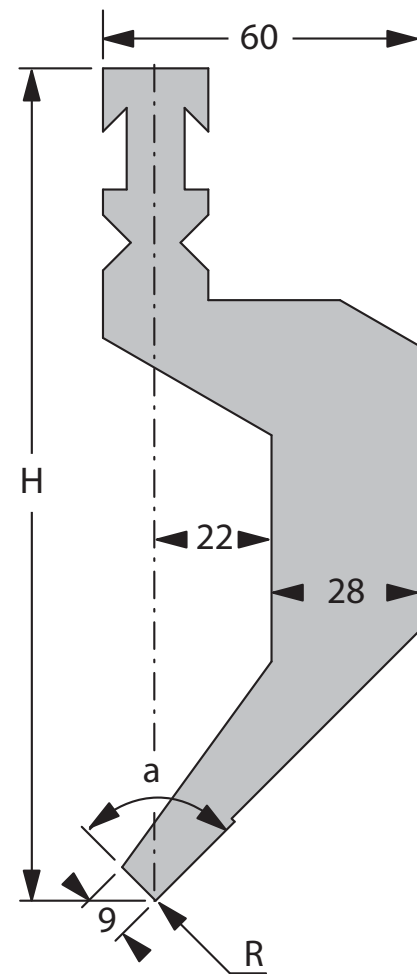

P4 RF-A / 85  
 $F = 900 \text{ kN/m}$   
 $R = 1.5 / 1 \text{ mm}$   
 $H = 175 \text{ mm}$

## P4 RF-A H250



[R] Radius (mm) 1.5

Nose angle 85°

[H] Height (mm) 250

 42 CrMo 4

 58 - 62 HRC

  $F_{max} = 600 \text{ kN/m}$

 Operator side

 Head supported

 48.3 kg/m

 Hydraulic clamping

 98.0 mm

 Ex stock / 24 h

 BOS No. BY1C012

Standard length	Part number
515 mm	65206.0004.5007
1030 mm	65206.0004.3009
1000 mm sect. FSC	65206.0004.0004
1100 mm sect. FSL	65206.0004.1003
Horn set LH + RH	65206.0004.7003

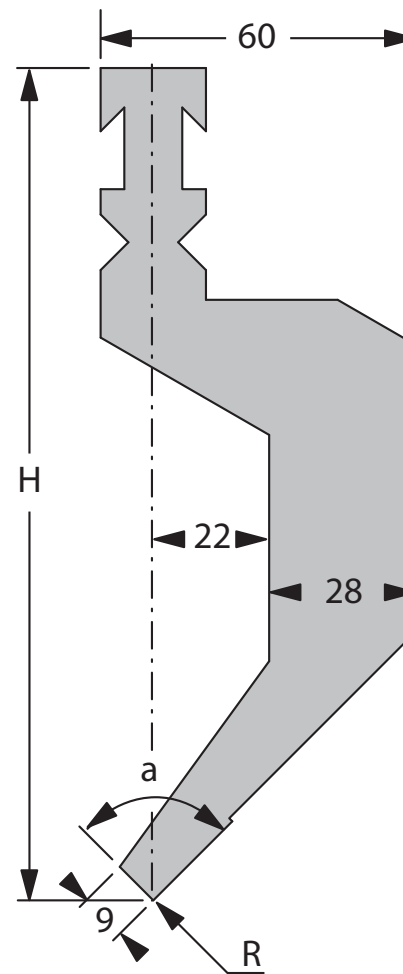

P4 RF-A / 85  
 $F = 600 \text{ kN/m}$   
 $R = 1.5 / 1 \text{ mm}$   
 $H = 250 \text{ mm}$

## P5 RF-A H175



[R] Radius (mm) 1

Nose angle 30°

[H] Height (mm) 175

 42 CrMo 4

 58 - 62 HRC

  $F_{max} = 1000 \text{ kN/m}$

 Operator side

 Head supported

 19 kg/m

 Hydraulic clamping

 45.5 mm

 Ex stock / 24 h

 BOS No. BY1C019

Standard length	Part number
515 mm	65206.0005.5007
1030 mm	65206.0005.3004
1000 mm sect. FSC	65206.0005.0003
1100 mm sect. FSL	65206.0005.1003
Horn set LH + RH	65206.0005.7002

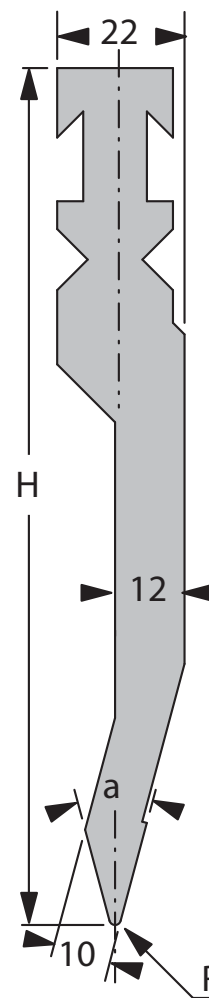

P5 RF-A / 30°  
 $F = 1000 \text{ kN/m}$   
 $R = 1 \text{ mm}$   
 $H = 175 \text{ mm}$

## P5 RF-A H250



[R] Radius (mm) 1

Nose angle 30°

[H] Height (mm) 250

 42 CrMo 4

 58 - 62 HRC

  $F_{max} = 750 \text{ kN/m}$

 Operator side

 Head supported

 26 kg/m

 Hydraulic clamping

 98.0 mm

 Ex stock / 24 h

 BOS No. BY1C020

Standard length	Part number
515 mm	65206.0005.5008
1030 mm	65206.0005.3005
1000 mm sect. FSC	65206.0005.0004
1100 mm sect. FSL	65206.0005.1002
Horn set LH + RH	65206.0005.7001

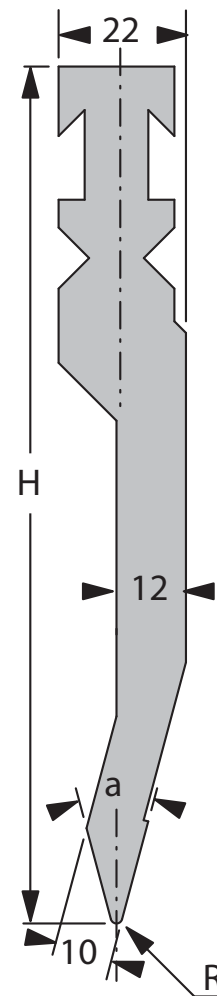

P5 RF-A / 30°  
 $F = 750 \text{ kN/m}$   
 $R = 1 \text{ mm}$   
 $H = 250 \text{ mm}$

## P6 RF-A H175



[R] Radius (mm) 1

Nose angle 30°

[H] Height (mm) 175

 42 CrMo 4

 58 - 62 HRC

  $F_{max} = 1500 \text{ kN/m}$

 Operator side

 Head supported

 23.3 kg/m

 Hydraulic clamping

 45.5 mm

 Ex stock / 24 h

**BOS No.** BY1C023

Standard length	Part number
515 mm	65206.0006.5001
1030 mm	65206.0006.3003
1000 mm sect. FSC	65206.0006.0001
1100 mm sect. FSL	65206.0006.1001
Horn set LH + RH	65203.0006.7002

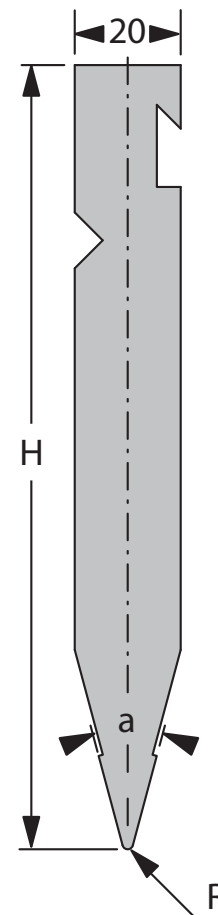

P6 RF-A / 30°  
 $F = 1500 \text{ kN/m}$   
 $R = 1 \text{ mm}$   
 $H = 175 \text{ mm}$

## P6 RF-A H250



[R] Radius (mm) 1

Nose angle 30°

[H] Height (mm) 250

 42 CrMo 4

 58 - 62 HRC

  $F_{max} = 1400 \text{ kN/m}$

 Operator side

 Head supported

 35 kg/m

 Hydraulic clamping

 98.0 mm

 Ex stock / 24 h

 BOS No. BY1C024

Standard length	Part number
515 mm	65206.0006.5002
1030 mm	65206.0006.3002
1000 mm sect. FSC	65206.0006.0002
1100 mm sect. FSL	65206.0006.1003
Horn set LH + RH	65206.0006.7001

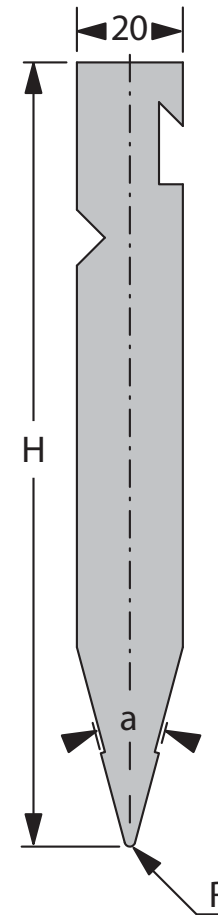

P6 RF-A / 30°  
 $F = 1400 \text{ kN/m}$   
 $R = 1 \text{ mm}$   
 $H = 250 \text{ mm}$



## P7 RF-A H175

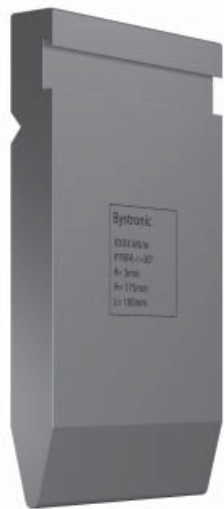

[R] Radius (mm) 3

Nose angle 30°

[H] Height (mm) 175

 42 CrMo 4

 58 - 62 HRC

  $F_{max} = 1600 \text{ kN/m}$

 Operator side

 Head supported

 24.2 kg/m

 Hydraulic clamping

 45.5 mm

 Ex stock / 24 h

**BOS No.** BY1C027

Standard length	Part number
515 mm	65206.0007.5002
1030 mm	65206.0007.3004
1000 mm sect. FSC	65206.0007.0003
1100 mm sect. FSL	65206.0007.1002
Horn set LH + RH	65206.0007.7001

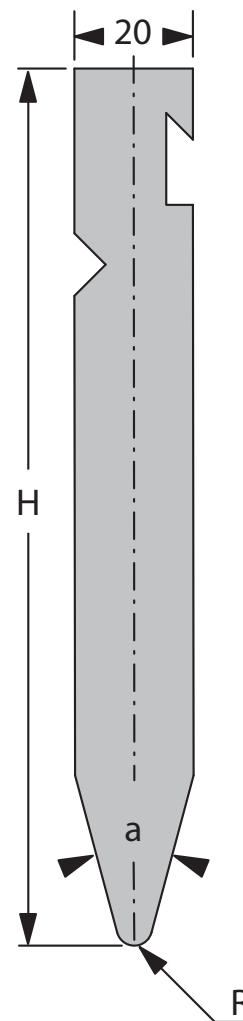

P7 RF-A / 30°  
 $F = 1600 \text{ kN/m}$   
 $R = 3 \text{ mm}$   
 $H = 175 \text{ mm}$

## P7 RF-A H250



[R] Radius (mm) 3

Nose angle 30°

[H] Height (mm) 250

 42 CrMo 4

 58 - 62 HRC

  $F_{max} = 1400 \text{ kN/m}$

 Operator side

 Head supported

 35.9 kg/m

 Hydraulic clamping

 98.0 mm

 Ex stock / 24 h

 BOS No. BY1C028

Standard length	Part number
515 mm	65206.0007.5003
1030 mm	65206.0007.3006
1000 mm sect. FSC	65206.0007.0002
1100 mm sect. FSL	65206.0007.1003
Horn set LH + RH	65206.0007.7002

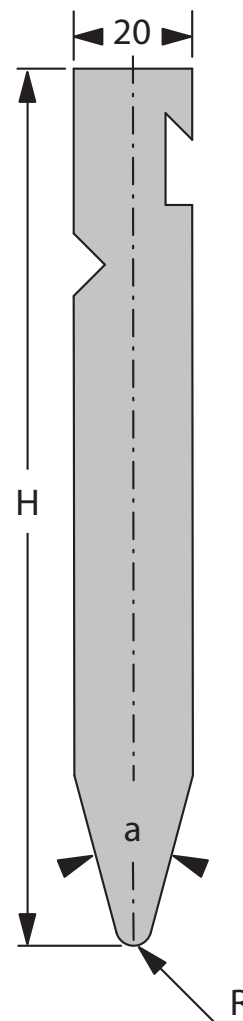

P7 RF-A / 30°  
 $F = 1400 \text{ kN/m}$   
 $R = 3 \text{ mm}$   
 $H = 250 \text{ mm}$

## P8 RF-A H175



[R] Radius (mm) 1

Nose angle 85°

[H] Height (mm) 175

 42 CrMo 4

 58 - 62 HRC

  $F_{max} = 1000 \text{ kN/m}$

 Operator side

 Head supported

 26.5 kg/m

 Hydraulic clamping

 45.5 mm

 Ex stock / 24 h

 BOS No. BY10123

Standard length	Part number
515 mm	65206.0008.5002
1030 mm	65206.0008.3003
1000 mm sect. FSC	65206.0008.0001
1100 mm sect. FSL	65206.0008.1003
Horn set LH + RH	65206.0008.7001

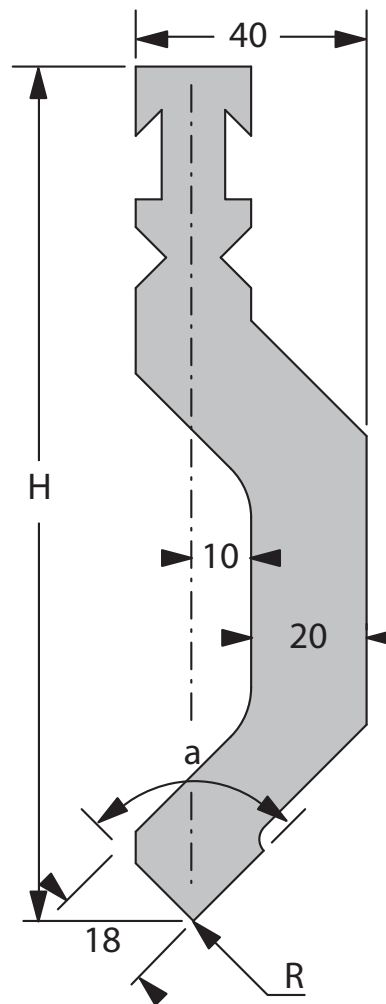

P8 RF-A / 85°  
 $F = 1000 \text{ kN/m}$   
 $R = 1 \text{ mm}$   
 $H = 175 \text{ mm}$

## P8 RF-A H250



[R] Radius (mm) 1

Nose angle 85°

[H] Height (mm) 250

 42 CrMo 4

 58 - 62 HRC

  $F_{max} = 1000 \text{ kN/m}$

 Operator side

 Head supported

 38.3 kg/m

 Hydraulic clamping

 98.0 mm

 Ex stock / 24 h

 BOS No. BY1C032

Standard length	Part number
515 mm	65206.0008.5013
1030 mm	65206.0008.3004
1000 mm sect. FSC	65206.0008.0004
1100 mm sect. FSL	65206.0008.1004
Horn set LH + RH	65206.0008.7002

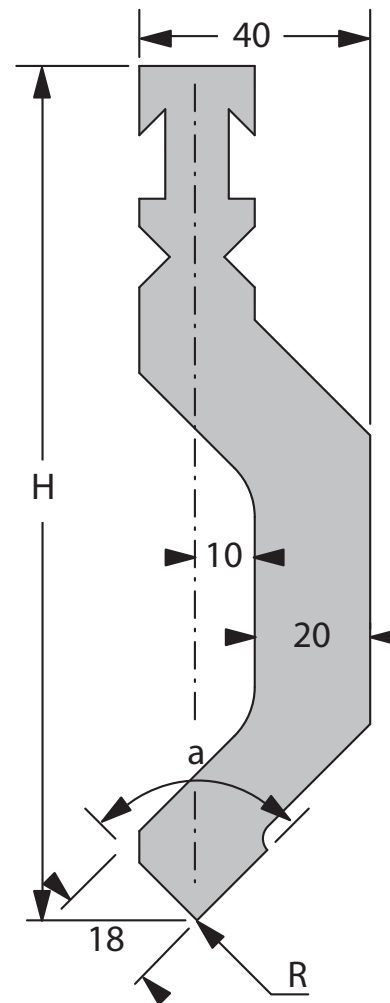

P8 RF-A / 85°  
 $F = 1000 \text{ kN/m}$   
 $R = 1 \text{ mm}$   
 $H = 250 \text{ mm}$

## P9 RF-A H175



[R] Radius (mm) 4

Nose angle 60°

[H] High (mm) 175

 42 CrMo 4

 58 - 62 HRC

  $F_{max} = 1600 \text{ kN/m}$

 Operator side

 Head supported

 33.5 kg/m

 Hydraulic clamping

 45.5 mm

 Ex stock / 24 h

 BOS No. BY1C039

Standardlänge	Part number
515 mm	65206.0009.5006
1030 mm	65206.0009.3003
1000 mm sect. FSC	65206.0009.0001
1100 mm sect. FSL	65206.0009.1004
Horn set LH + RH	65206.0009.7001

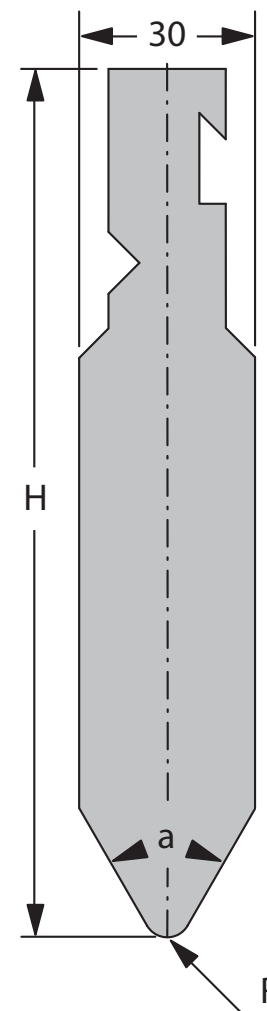

P9 RF-A / 60°  
 $F = 1600 \text{ kN/m}$   
 $R = 4 \text{ mm}$   
 $H = 175 \text{ mm}$

## P9 RF-A H250





[R] Radius (mm) 4

Nose angle 60°

[H] Height (mm) 250

 42 CrMo 4

 58 - 62 HRC

  $F_{max} = 1600 \text{ kN/m}$

 Operator side

 Head supported

 51 kg/m

 Hydraulic clamping

 98.0 mm

 Ex Stock / 24 h

 BOS No. BY1C040

Standard length	Part number
515 mm	65206.0009.5005
1030 mm	65206.0009.3004
1000 mm sect. FSC	65206.0009.0002
1100 mm sect. FSL	65206.0009.1003
Horn set LH + RH	65206.0009.7002

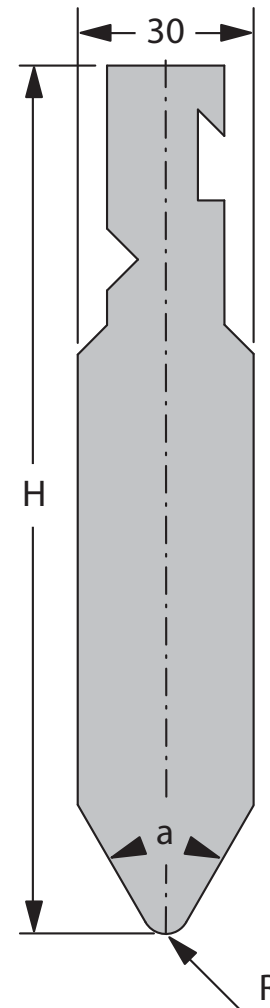

P9 RF-A / 60°  
 $F = 1600 \text{ kN/m}$   
 $R = 4 \text{ mm}$   
 $H = 250 \text{ mm}$

## P10 RF-A H150



[R] Radius (mm) -

Nose angle -

[H] Height (mm) 150

C45

---

Fmax = 1600 kN/m

Operator side

Head supported

34 kg/m

Hydraulic clamping

---

Ex stock / 24 h

**BOS No.** BY1C043A

Standard length	Part number
515 mm	65206.0010.5004
1030 mm	65206.0010.3004

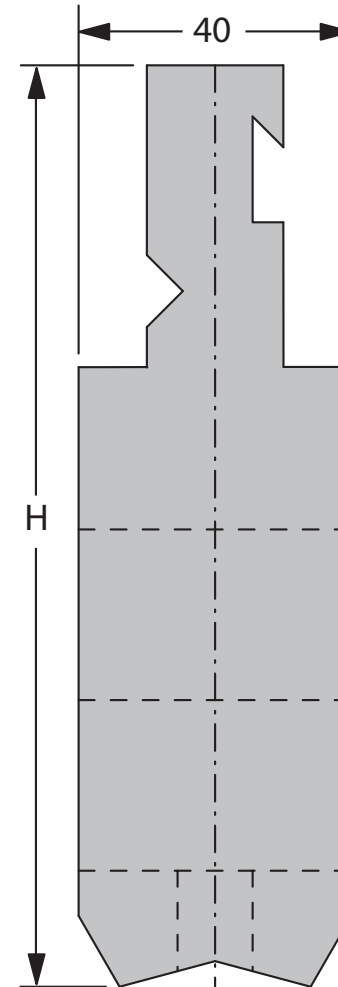

P10 RF-A  
F = 1600 kN/m  
H = 150 mm

## P10 RF-A H250



[R] Radius (mm) -

Nose angle -

[H] Height (mm) 250

	C45
	---
	Fmax = 1600 kN/m
	Operator side
	Head supported
	66 kg/m
	Hydraulic clamping
	---
	Ex stock / 24 h
	BY50026

Standard length	Part number
515 mm	65206.0010.5005
1030 mm	65206.0010.3003

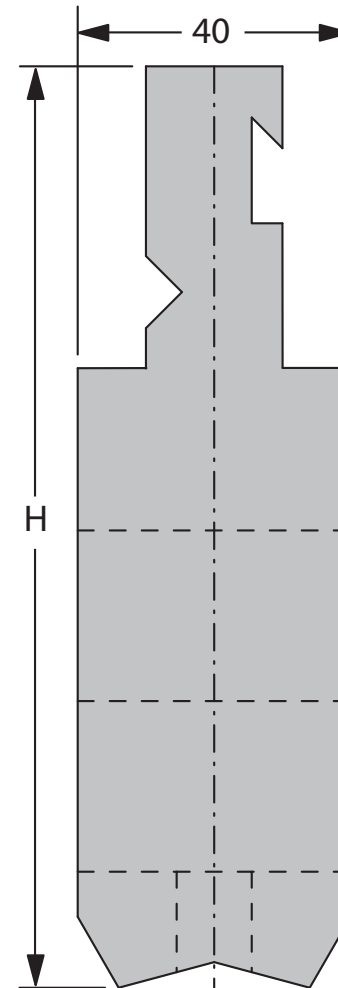

P10 RF-A  
F = 1600 kN/m  
H = 250 mm



## P10 RF-A

Round bars suitable for radius bar holder

Hardened radius bars

L	515/1030	515/1030	515/1030	515/1030	515/1030	515/1030
Type	PB 28	PB 30	PB 35	PB 40	PB 45	PB 50
Ø mm	28	30	35	40	45	50
G	5	5.5	7.5	10	12.5	15.5

515/1030	515/1030	515/1030	515/1030	515/1030
PB 55	PB 60	PB 65	PB 70	PB 80
55	60	65	70	80
18.5	22	26	30	39.5

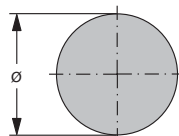

42CrMo4/60 - 62 HRC

Non hardened radius bars of C45 steel (ground) are also available.

## P10 RF-A

Round bars suitable for radius bar holder

Length	Ø Round bars	Part number
515 mm	28 mm	65200.0028.5002
	30 mm	65200.0030.5007
	35 mm	65200.0035.5005
	40 mm	65200.0040.5005
	45 mm	65200.0045.5003
	50 mm	65200.0050.5009
	55 mm	65200.0055.5002
	60 mm	65200.0060.5004
	65 mm	65200.0065.5002
1030 mm	70 mm	65200.0070.5001
	80 mm	65200.0080.5003
	28 mm	65200.0028.3002
	30 mm	65200.0030.3007
	35 mm	65200.0035.3002
	40 mm	65200.0040.3006
	45 mm	65200.0045.3002
	50 mm	65200.0050.3005
	55 mm	65200.0055.3001
60 mm	65200.0060.3004	
65 mm	65200.0065.3001	
70 mm	65200.0070.3003	
80 mm	65200.0080.3004	

## P11 RF-A H175





[R] Radius (mm) -

Nose angle -

[H] Height (mm) 175

 42 CrMo 4

 58 - 62 HRC

  $F_{max} = 1600 \text{ kN/m}$

 Operator side

 Head supported

 26.7 kg/m

 Hydraulic clamping

 ---

 Ex stock / 24 h

**BOS No.** BY1C057

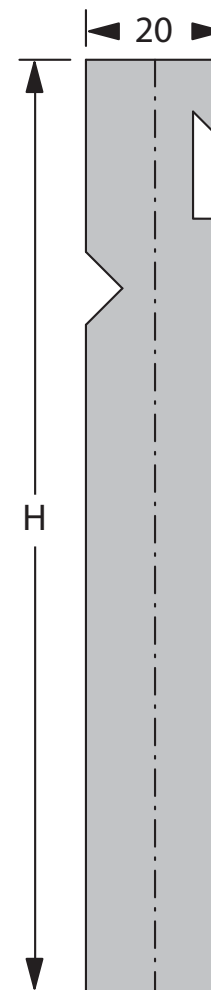

P11 RF-A  
 $F = 1600 \text{ kN/m}$   
 $H = 175 \text{ mm}$

Standard length	Part number
515 mm	65206.0011.5004
1030 mm	65206.0011.3001
1000 mm sect. FSC	65206.0011.0002
1100 mm sect. FSL	65206.0011.1001











## P11 RF-A H250



[R] Radius (mm) -

Nose angle -

[H] Height (mm) 250

	42 CrMo 4
	58 - 62 HRC
	F <sub>max</sub> = 1600 kN/m
	Operator side
	Head supported
	38.5 kg/m
	Hydraulic clamping
	---
	Ex stock / 24 h
	BY1C058

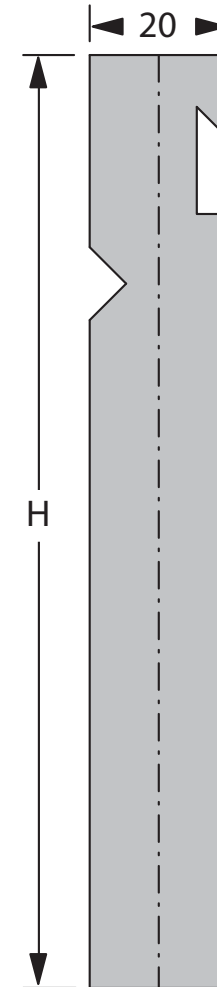

P11 RF-A  
F = 1600 kN/m  
H = 250 mm

### Standard length

### Part number

515 mm	65206.0011.5003
1030 mm	65206.0011.3002
1000 mm sect. FSC	65206.0011.0001
1100 mm sect. FSL	65206.0011.1002

## P12 RF-A H130



[R] Radius (mm) -

Nose angle -

[H] Height (mm) 130

C45

---

1600 kN/m

Operator side

Head supported

33 kg/m

Hydraulic clamping

---

Ex stock / 24 h

**BOS No.** BY1C061

Standard length	Part number
515 mm	65206.0012.5001
1030 mm	65206.0012.3002
1000 mm sect. FSC	65206.0012.0002
1100 mm sect. FSL	65206.0012.1001

H1 = 44 mm  
H2 = 35mm  
(standard)

P12 RF-A  
F = 1600 kN/m  
H = 130 mm

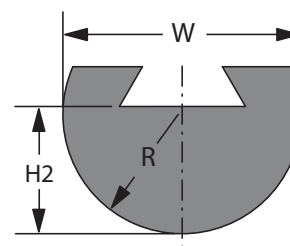

Typ B

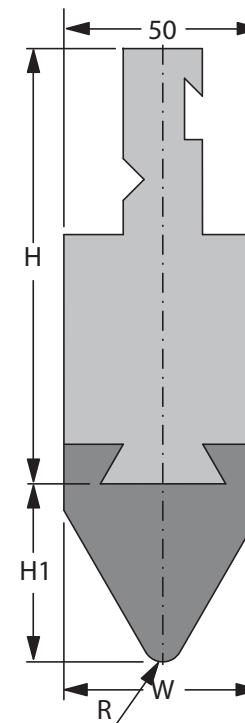

Typ A

## P12 Radius tools

42CrMo4 hardened

Radius	Weight	Length	Part number	
R= 5	Type A	6,6 kg	515 mm	65200.0005.5002
		13,1 kg	1030 mm	65200.0005.3002
		12,7 kg	1000 mm SECT. FSC	65200.0005.0002
		14,0 kg	1100 mm SECT. FSL	65200.0005.1002
R= 6	Type A	6,6 kg	515 mm	65200.0006.5005
		13,1 kg	1030 mm	65200.0006.3003
		12,7 kg	1000 mm SECT. FSC	65200.0006.0003
		14,0kg	1100 mm SECT. FSL	65200.0006.1002
R= 8	Type A	6,6 kg	515 mm	65200.0008.5003
		13,1 kg	1030 mm	65200.0008.3002
		12,7 kg	1000 mm SECT. FSC	65200.0008.0003
		14,0 kg	1100 mm SECT. FSL	65200.0008.1003
R= 10	Type A	6,6 kg	515 mm	65200.0010.5004
		13,1 kg	1030 mm	65200.0010.3002
		12,7 kg	1000 mm SECT. FSC	65200.0010.0003
		14,0 kg	1100 mm SECT. FSL	65200.0010.1003
R= 12	Type A	6,6 kg	515 mm	65200.0012.5005
		13,1 kg	1030 mm	65200.0012.3002
		12,7 kg	1000 mm SECT. FSC	65200.0012.0001
		14,0 kg	1100 mm SECT. FSL	65200.0012.1002
R= 15	Type A	6,6 kg	515 mm	65200.0015.5002
		13,1 kg	1030 mm	65200.0015.3002
		12,7 kg	1000 mm SECT. FSC	65200.0015.0003
		14,0 kg	1100 mm SECT. FSL	65200.0015.1003
R= 20	Type A	6,6 kg	515 mm	65200.0020.5004
		13,1 kg	1030 mm	65200.0020.3005
		12,7 kg	1000 mm SECT. FSC	65200.0020.0001
		14,0 kg	1100 mm SECT. FSL	65200.0020.1002
R= 25	Type B	6,6 kg	515 mm	65200.0025.5005
		13,1 kg	1030 mm	65200.0025.3002
		12,7 kg	1000 mm SECT. FSC	65200.0025.0001
		14,0 kg	1100 mm SECT. FSL	65200.0025.1002
R= 30	Type B	6,6 kg	515 mm	65200.0030.5004
		13,1 kg	1030 mm	65200.0030.3006
		12,7 kg	1000 mm SECT. FSC	65200.0030.0002
		14,0 kg	1100 mm SECT. FSL	65200.0030.1002
R= 35	Type B	6,6 kg	515 mm	65200.0035.5003
		13,1 kg	1030 mm	65200.0035.3001
		12,7 kg	1000 mm SECT. FSC	65200.0035.0001
		14,0 kg	1100 mm SECT. FSL	65200.0035.1001

## P12 Radius tools

C45 unhardened , ground

Radius	Weigth	Length	Part number	
R= 5	Type A	6,6 kg	515 mm	65200.0005.5001
		13,1 kg	1030 mm	65200.0005.3001
		12,7 kg	1000 mm SECT. FSC	65200.0005.0001
		14,0 kg	1100 mm SECT. FSL	65200.0005.1001
R= 6	Type A	6,6 kg	515 mm	65200.0006.5001
		13,1 kg	1030 mm	65200.0006.3001
		12,7 kg	1000 mm SECT. FSC	65200.0006.0001
		14,0 kg	1100 mm SECT. FSL	65200.0006.1001
R=8	Type A	6,9 kg	515 mm	65200.0008.5001
		13,8 kg	1030 mm	65200.0008.3001
		13,4 kg	1000 mm SECT.	65200.0008.0002
		14,8 kg	1100 mm SECT.	65200.0008.1001
R=10	Type A	7,2 kg	515 mm	65200.0010.5001
		14,4 kg	1030 mm	65200.0010.3001
		14 kg	1000 mm SECT. FSC	65200.0010.0001
		15,4 kg	1100 mm SECT. FSL	65200.0010.1001
R=12	Type A	7,5 kg	515 mm	65200.0012.5001
		14,9 kg	1030 mm	65200.0012.3001
		14,5 kg	1000 mm SECT. FSC	65200.0012.0002
		16,0 kg	1100 mm SECT. FSL	65200.0012.1001
R=15	Type A	7,9 kg	515 mm	65200.0015.5001
		15,7 kg	1030 mm	65200.0015.3001
		15,2 kg	1000 mm SECT. FSC	65200.0015.0001
		16,7 kg	1100 mm SECT. FSL	65200.0015.1001
R=20	Type A	8,4 kg	515 mm	65200.0020.5003
		16,7 kg	1030 mm	65200.0020.3003
		16,2 kg	1000 mm SECT. FSC	65200.0020.0002
		17,8 kg	1100 mm SECT. FSL	65200.0020.1001
R= 25	Type B	4,8 kg	515 mm	65200.0025.5004
		9,5 kg	1030 mm	65200.0025.3001
		9,2 kg	1000 mm SECT. FSC	65200.0025.0002
		10,1 kg	1100 mm SECT. FSL	65200.0025.1001
R=30	Type B	7 kg	515 mm	65200.0030.5003
		14,0 kg	1030 mm	65200.0030.3003
		13,6 kg	1000 mm SECT. FSC	65200.0030.0001
		15,0 kg	1100 mm SECT. FSL	65200.0030.1001
R=35	Type B	9,5 kg	515 mm	65200.0035.5002
		19,0 kg	1030 mm	65200.0035.3003
		18,4 kg	1000 mm SECT. FSC	65200.0035.0002
		20,3 kg	1100 mm SECT. FSL	65200.0035.1002

# P13 RF-A



42 CrMo 4

58 - 62 HRC

Fmax = 1000 kN/m

Operator side

Head supported

kg/m

Hydraulic clamping

Variable (Edge)

Ex stock / 24 h

**BOS No.** IB00674E

[R] Radius (mm) -

Nose angle -

[H] Height (mm)

Combination between  
Hämmerle + Xpert tools

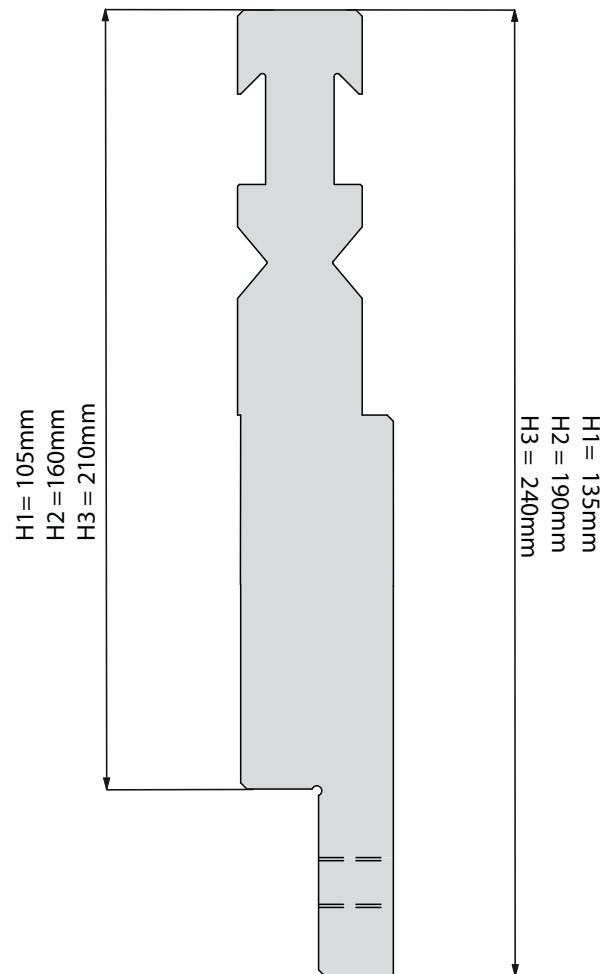

## P13 RF-A

### Overview

Model	Length	Part number
P13 RFA H1/ IB00674D	50 mm	65206.0013.5001
	55 mm	65206.0013.5002
	60 mm	65206.0013.5003
	65mm	65206.0013.5004
	Horn 70mm	65206.0013.5005
	80 mm	65206.0013.5006
	85 mm	65206.0013.5007
	90 mm	65206.0013.5008
	95 mm	65206.0013.5009
	100 mm	65206.0013.5010
	200 mm	65206.0013.5011
	500 mm	65206.0013.5012
	1000 mm sect.	65206.0013.0001
75 mm	65206.0013.5039	

1000 sect. = 50mm, 55mm, 60mm, 2x 65mm, 70mm Horn, 80mm, 90mm, 95mm, 100mm, 200mm

Model	Length	Part number
P13 RFA H2/ IB00696D	50 mm	65206.0013.5013
	55 mm	65206.0013.5014
	60 mm	65206.0013.5015
	65mm	65206.0013.5016
	Horn 70mm	65206.0013.5017
	80 mm	65206.0013.5018
	85 mm	65206.0013.5019
	90 mm	65206.0013.5020
	95 mm	65206.0013.5021
	100 mm	65206.0013.5022
	200 mm	65206.0013.5023
	500 mm	65206.0013.5024
	1000 mm sect.	65206.0013.0002
75 mm	65206.0013.5038	

1000 sect. = 50mm, 55mm, 60mm, 2x 65mm, 70mm Horn, 80mm, 90mm, 95mm, 100mm, 200mm

## P13 RF-A

### Overview

Model	Length	Part number
P13 RFA H3/ IB00697F	50 mm	65206.0013.5025
	55 mm	65206.0013.5026
	60 mm	65206.0013.5027
	65mm	65206.0013.5028
	Horn 70mm	65206.0013.5029
	80 mm	65206.0013.5030
	85 mm	65206.0013.5031
	90 mm	65206.0013.5032
	95 mm	65206.0013.5033
	100 mm	65206.0013.5034
	200 mm	65206.0013.5035
	500 mm	65206.0013.5036
	1000 mm sect.	65206.0013.0003
75 mm	65206.0013.5037	

1000 sect. = 50mm, 55mm, 60mm, 2x 65mm, 70mm Horn, 80mm, 90mm, 95mm, 100mm, 200mm

## Adapter P25 Xpert/Euro B



[R] Radius (mm) -

Nose angle -

[H] Height (mm) 130/250

Length (mm) 150

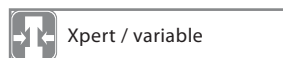
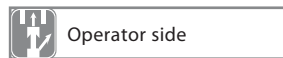
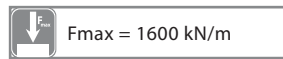

Type	Height (mm)	Weight (kg/ m)	Psrt number
P25 R	105	16	64600.000.0072
P25 RF	130	20	64600.000.0072
P25 RF	200	31	64600.000.0073
P25 RF-A	130	20	64600.000.0033
P25 RF- A	250	38.8	64600.000.0037

## Example: R / Euro B

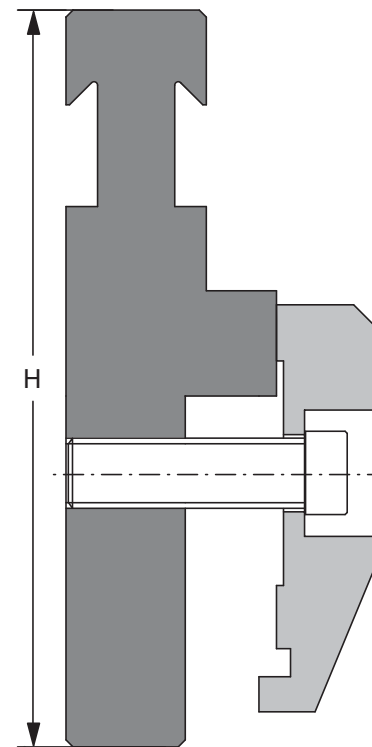



## Extension P30



[R] Radius (mm) -

Nose angle -

[H] Height (mm) variable

Length (mm) 150

C45

---

$F_{max} = 1600 \text{ kN/m}$

Operator side

Head supported

see down below

Xpert / variable

---

Ex stock / 24 h

BOS No. ---

Type	High H / H1 in mm	Weight in kg / m	Part number
P30 R	139/100	43	64600.0000.0025
P30 RF	184/125	46.9	64600.0000.0049
P30 RF	259/200	58.7	64600.0000.0039
P30 RF-A	184/125	46.9	64600.0000.0024
P30 RF-A	309/250	66.5	64600.0000.0032

## Example: RF-A / RF

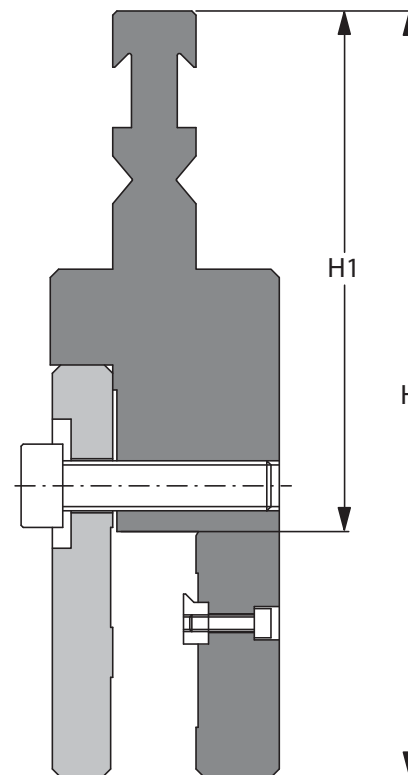

# Bottom tools Xpert



## Bottom tools Xpert

### Recommendation starterkit Xpert 60 - 320

Bend length	Part number	Designation	Pieces	Unit
2050 mm	65206.0005.5007	Punch P5 RF-A/30° L=515	4	pieces
	65206.0005.0003	Punch P5 RF-A/30° L=1000 sect. FSC	1	piece
	64201.0012.3009	Die V12/30° L=1030	2	pieces
	64201.0012.0002	Die V12/30° L=1000 sect.FSC	1	piece
2550 mm	65206.0005.5007	Punch P5 RF-A/30° L=515	5	pieces
	65206.0005.0003	Punch P5 RF-A/30° L=1000 sect. FSC	1	piece
	64201.0012.3009	Die V12/30° L=1030	2	pieces
	64201.0012.0002	Die V12/30° L=1000 sect.FSC	1	piece
3100 mm	65206.0005.5007	Punch P5 RF-A/30° L=515	6	pieces
	65206.0005.0003	Punch P5 RF-A/30° L=1000 sect. FSC	1	piece
	64201.0012.3009	Die V12/30° L=1030	3	pieces
	64201.0012.0002	Die V12/30° L=1000 sect.FSC	1	piece
4100 mm	65206.0005.5007	Punch P5 RF-A/30° L=515	8	pieces
	65206.0005.0003	Punch P5 RF-A/30° L=1000 sect. FSC	1	piece
	64201.0012.3009	Die V12/30° L=1030	4	pieces
	64201.0012.0002	Die V12/30° L=1000 sect.FSC	1	piece

## Lower table options

### Tables with mechanical tool clamping

T5  
(Standard Xpert 60 – 320)

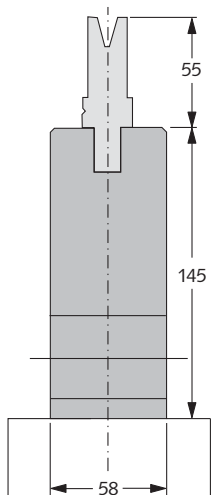

Fitting bottom tools  
up to V80.

T55  
(Standard Xpert 250 – 1000)

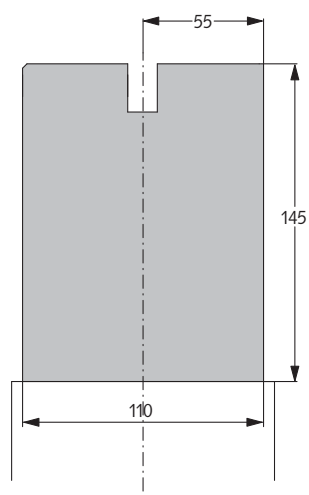

Fitting bottom tools  
up to V150.

## Lower table options

### Table with hydraulic tool clamping

T12  
(Optional Xpert 60 - 320 and  
Xpert 250 - 1000)

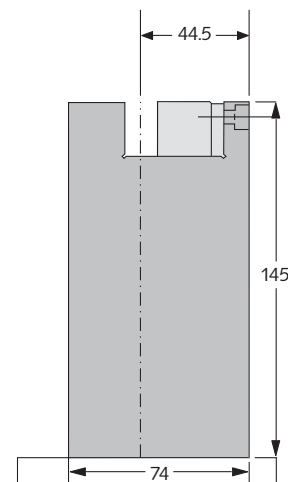

Fitting bottom tools  
up to V80.

T13  
(Optional Xpert 60 - 320 and  
Xpert 250 - 1000)

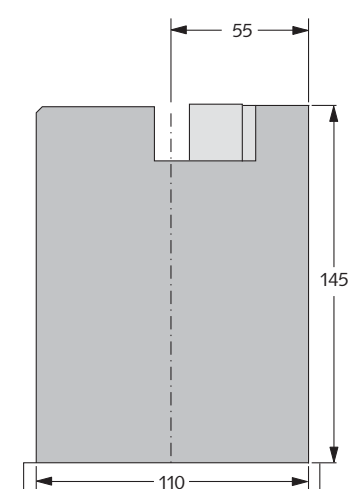

Fitting bottom tools  
up to V150.

## Lower table options

### Tables for larger bottom tools

T2

(Standard Xpert MAMMUT and  
Optional Xpert 250 - 1000)\*

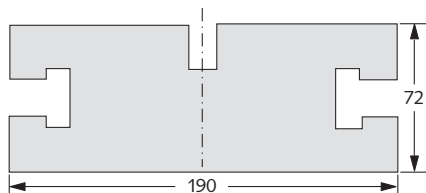

Fitting bottom tools  
up to V250.

\* this table is ideal to use adapter's (for example S1),  
large bottom tools or with V bottom tools.

## Lower table options

### Hydraulic dutch bending table

T8

(Optional for Xpert 60 - 320, but only on special request)

up to 3mm mild steel thickness

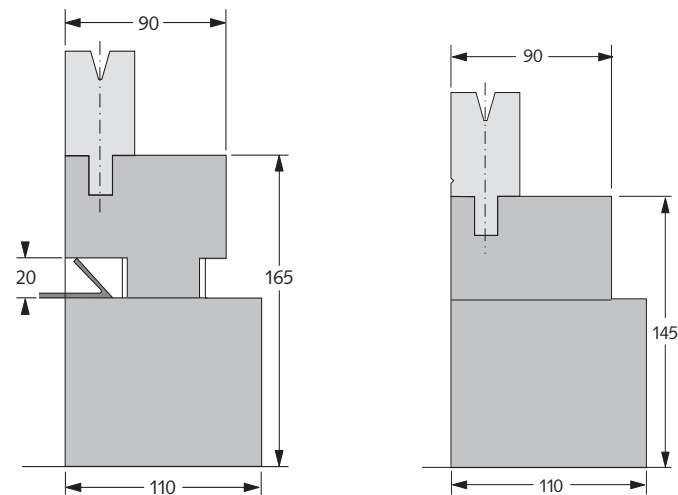

open

closed

## Lower table options

### Hydraulic dutch bending table with hydraulic die clamping

T9  
(Optional for Xpert 60 - 320)

up to 2mm material thickness

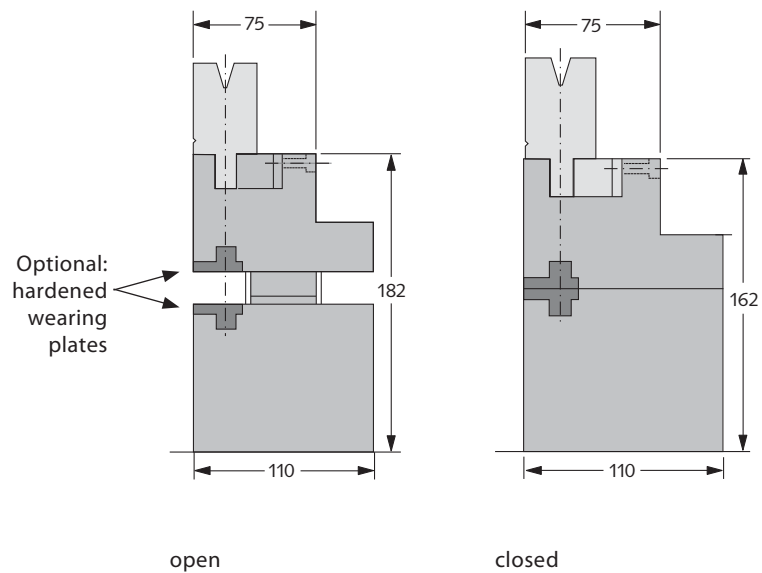

This table combines the high productivity of the hydraulic tool clamping with the flexibility of dutch bending.

## Lower die options

### Bottom tool segmentation

Segmentation FSC/1000 mm  
(10 + 15 + 20 + 30 + 50 + 100 + 200 + 275 + 300)

10	15	20	30	50	100	200	275	300
----	----	----	----	----	-----	-----	-----	-----

FSL/1100 mm  
(10 + 15 + 20 + 30 + 50 + 100 + 200 + 375 + 300)

10	15	20	30	50	100	200	375	300
----	----	----	----	----	-----	-----	-----	-----

Special segmentation on request.

In addition all lower dies can be supplied with modified radii, die angle and height (non standard).

## V6/30°

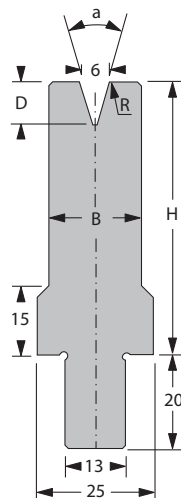

[R] Radius (mm) 0.75

[a] V - Angle 30°

[H] Height (mm) 55

[B] Width (mm) 20

[D] Depth (mm) 9.3

Weight / Meter 10.9 Kg

Standard length	Part number
515 mm	64201.0006.5004
1030 mm	64201.0006.3008
1000 mm sect. FSC	64201.0006.0001
1100 mm sect. FSL	64201.0006.1002

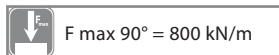
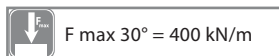
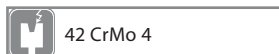

## V8/30°

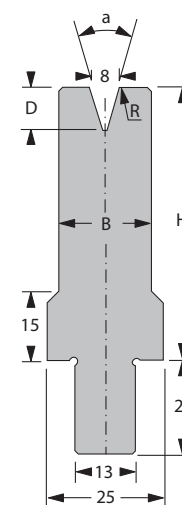
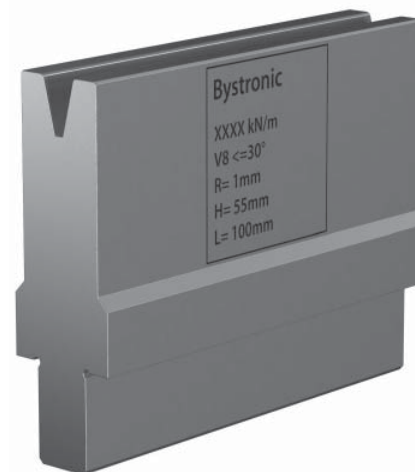

[R] Radius (mm) 1

[a] V - Angle 30°

[H] Height (mm) 55

[B] Width (mm) 20

[D] Depth (mm) 11.2

Weight / Meter 10.8 Kg

Standard length	Part number
515 mm	64201.0008.5012
1030 mm	64201.0008.3005
1000 mm sect. FSC	64201.0008.0001
1100 mm sect. FSL	64201.0008.1002

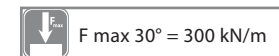
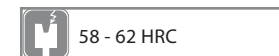
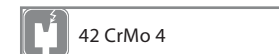

## V10/30°

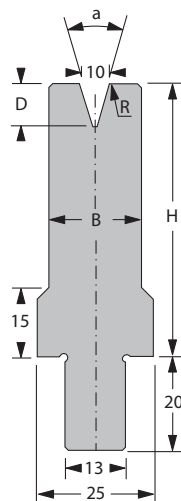

[R] Radius (mm)	1
[a] V - Angle	30°
[H] Height (mm)	55
[B] Width (mm)	20
[D] Depth (mm)	14.9
Weight / Meter	10.6 Kg

Standard length	Part number
515 mm	64201.0010.5016
1030 mm	64201.0010.3006
1000 mm sect. FSC	64201.0010.0004
1100 mm sect. FSL	64201.0010.1002

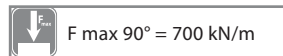
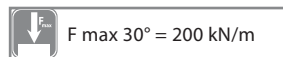

## V12/30°

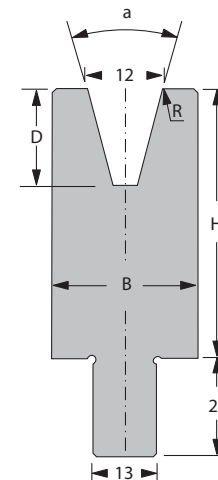

[R] Radius (mm)	1.5
[a] V - Angle	30°
[H] Height (mm)	55
[B] Width (mm)	25
[D] Depth (mm)	18.6
Weight / Meter	11.8 Kg

Standard length	Part number
515 mm	64201.0012.5007
1030 mm	64201.0012.3009
1000 mm sect. FSC	64201.0012.0002
1100 mm sect. FSL	64201.0012.1002

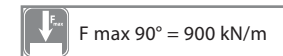
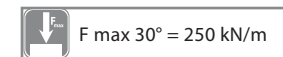
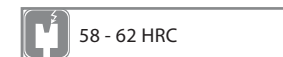
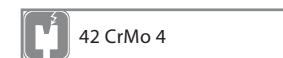

## V16/30°

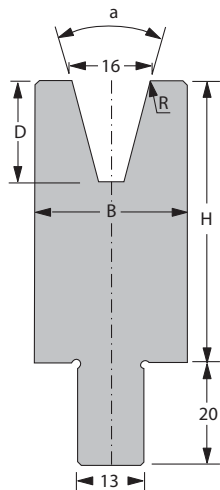

[R] Radius (mm)	2
[a] V - Angle	30°
[H] Height (mm)	55
[B] Width (mm)	30
[D] Depth (mm)	20.5
Weight / Meter	13.3 Kg

Standard length	Part number
515 mm	64201.0016.5011
1030 mm	64201.0016.3006
1000 mm sect. FSC	64201.0016.0001
1100 mm sect. FSL	64201.0016.1002

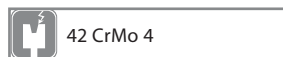

42 CrMo 4



58 - 62 HRC

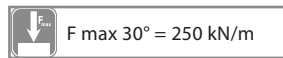

F max 30° = 250 kN/m

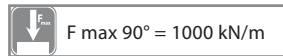

F max 90° = 1000 kN/m



Die insert 13 mm



Ex stock / 24 h



BOS No. BY2C019

## V20/30°

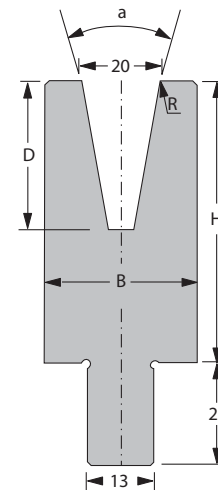

[R] Radius (mm)	2.5
[a] V - Angle	30°
[H] Height (mm)	55
[B] Width (mm)	30
[D] Depth (mm)	28
Weight / Meter	12.2 Kg

Standard length	Part number
515 mm	64201.0020.5002
1030 mm	64201.0020.3007
1000 mm sect. FSC	64201.0020.0002
1100 mm sect. FSL	64201.0020.1001

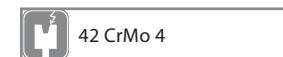

42 CrMo 4

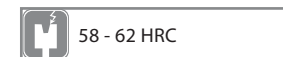

58 - 62 HRC

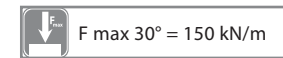

F max 30° = 150 kN/m

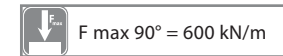

F max 90° = 600 kN/m



Die insert 13 mm



Ex stock / 24 h



BOS No. BY20002



## V24/30°

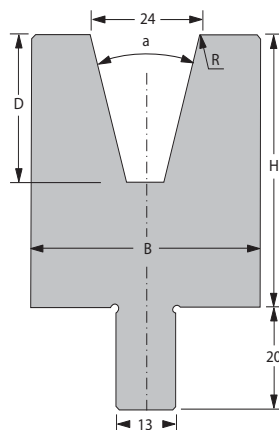

[R] Radius (mm)	3
[a] V - Angle	30°
[H] Height (mm)	55
[B] Width (mm)	40
[D] Depth (mm)	29.8
Weight / Meter	15.5 Kg

Standard length	Part number
515 mm	64201.0024.5010
1030 mm	64201.0024.3005
1000 mm sect. FSC	64201.0024.0001
1100 mm sect. FSL	64201.0024.1002

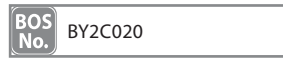
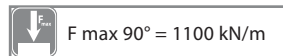
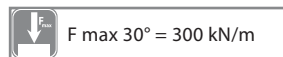
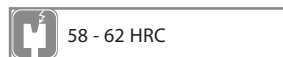
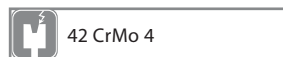

## V32/30° \*

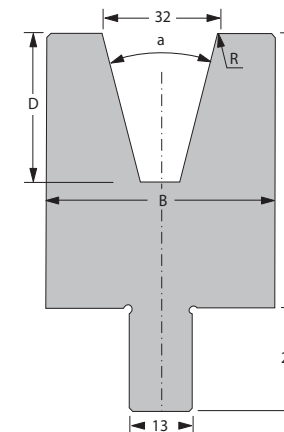

[R] Radius (mm)	4
[a] V - Angle	30°
[H] Height (mm)	55
[B] Width (mm)	48
[D] Depth (mm)	33.6
Weight / Meter	16.7 Kg

Standard length	Part number
515 mm	64201.0032.5010
1030 mm	64201.0032.3006
1000 mm sect. FSC	64201.0032.0002
1100 mm sect. FSL	64201.0032.1002

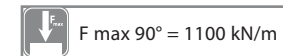
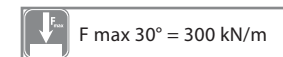
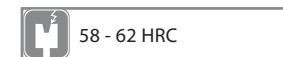
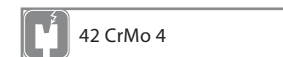

\* Also available with rolls.

## V40/60° \*

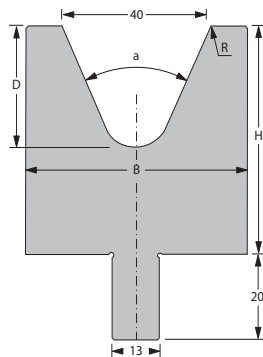

[R] Radius (mm)	5
[a] V - Angle	60°
[H] Height (mm)	55
[B] Width (mm)	55
[D] Depth (mm)	29.6
Weight / Meter	20.5 Kg

Standard length	Part number
515 mm	64201.0040.5003
1030 mm	64201.0040.3007
1000 mm sect. FSC	64201.0040.0002
1100 mm sect. FSL	64201.0040.1001

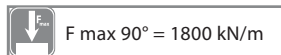
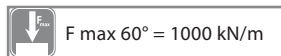
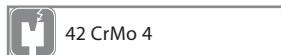

\* Also available with rolls.

## V50/60° \*

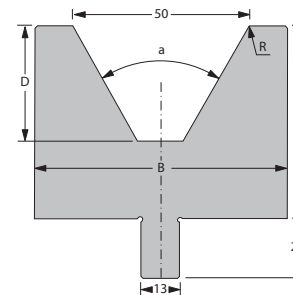

[R] Radius (mm)	5
[a] V - Angle	60°
[H] Height (mm)	55
[B] Width (mm)	70
[D] Depth (mm)	30.3
Weight / Meter	24.5 Kg

Standard length	Part number
515 mm	64201.0050.5003
1030 mm	64201.0050.3003
1000 mm sect. FSC	64201.0050.0001
1100 mm sect. FSL	64201.0050.1001

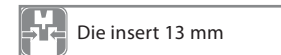
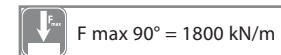
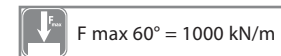
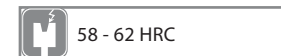
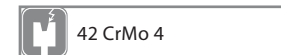

\* Also available with rolls.

## V60/60° \*

100

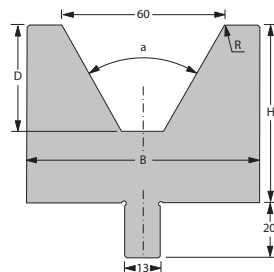

[R] Radius (mm)	7
[a] V - Angle	60°
[H] Height (mm)	65
[B] Width (mm)	80
[D] Depth (mm)	39
Weight / Meter	31.4 Kg

Standard length	Part number
515 mm	64201.0060.5005
1030 mm	64201.0060.3005
1000 mm sect. FSC	64201.0060.0002
1100 mm sect. FSL	64201.0060.1001

\* Also available with rolls.

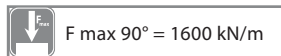
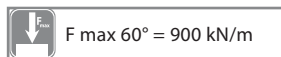

## V80/80° \*

101

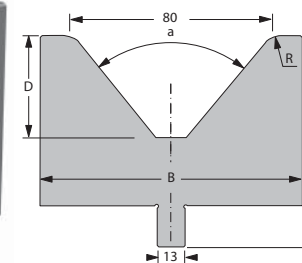
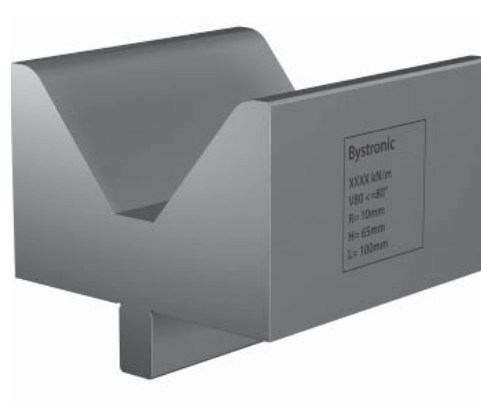

[R] Radius (mm)	10
[a] V - Angle	80°
[H] Height (mm)	65
[B] Width (mm)	100
[D] Depth (mm)	38.7
Weight / Meter	38.6 Kg

Standard length	Part number
515 mm	64201.0080.5002
1030 mm	64201.0080.3005
1000 mm sect. FSC	64201.0080.0001
1100 mm sect. FSL	64201.0080.1002

\* Also available with rolls.

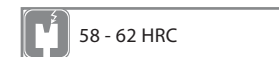
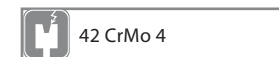

## V100/80° \*

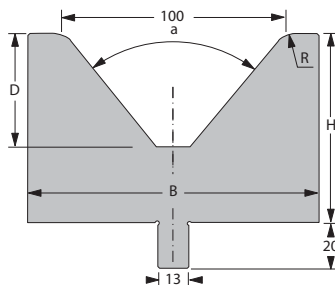

[R] Radius (mm) 12

[a] V - Angle 80°

[H] Height (mm) 85

[B] Width (mm) 125

[D] Depth (mm) 50.5

Weight / Meter 62.5 Kg

Standard length	Part number
515 mm	64201.0100.5004
1030 mm	64201.0100.3005
1000 mm sect. FSC	64201.0100.0001
1100 mm sect. FSL	64201.0100.1001

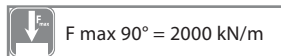
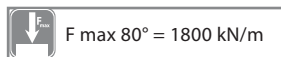
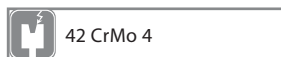

\* Also available with rolls.

## V120/80° \*

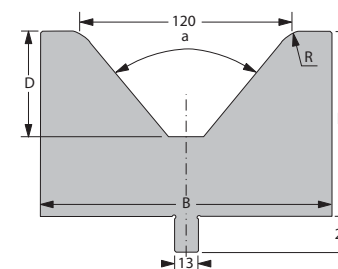

[R] Radius (mm) 15

[a] V - Angle 80°

[H] Height (mm) 105

[B] Width (mm) 160

[D] Depth (mm) 59.5

Weight / Meter 101 Kg

Standard length	Part number
515 mm	64201.0120.5002
1030 mm	64201.0120.3004
1000 mm sect. FSC	64201.0120.0001
1100 mm sect. FSL	64201.0120.1001

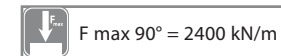
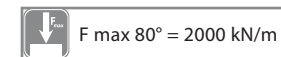
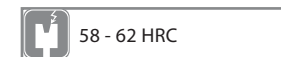
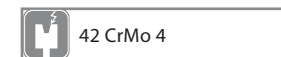

\* Also available with rolls.

## S1/73

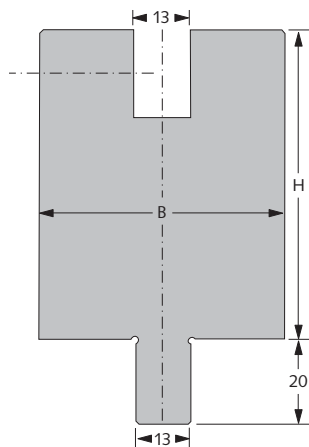

[R] Radius (mm)	-
V - Angle	-
[H] Height (mm)	73
[B] Width (mm)	58
[D] Depth (mm)	22
Weight / Meter	33 Kg

Standard length	Part number
515 mm	64201.0001.5008
1030 mm	64201.0001.3003
1000 mm sect. FSC	64201.0001.0003
1100 mm sect. FSL	64201.0001.1001

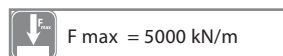

## S1/100

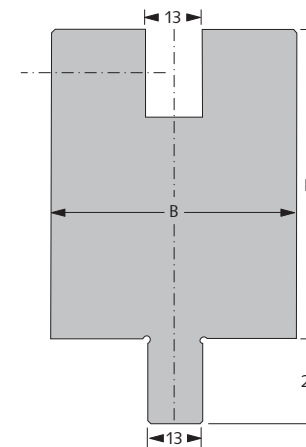

[R] Radius (mm)	-
V - Angle	-
[H] Height (mm)	100
[B] Width (mm)	58
[D] Depth (mm)	22
Weight / Meter	45.3 Kg

Standard length	Part number
515 mm	64201.0001.5006
1030 mm	64201.0001.3004
1000 mm sect. FSC	64201.0001.0001
1100 mm sect. FSL	64201.0001.1002

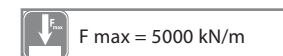

## Hemming tools air bending

### Hemming tool P900 (upper tool)

P900

$L = 515 / 1030$      $S = 1000 / 1100$      $R = 1$      $\alpha = 30^\circ$

	P900 R			P900 RF			P900 RF-A		
H	175			175			175		
B	6	8	10	6	8	10	6	8	10
G	22	22.8	21	24	24.6	25.2	23	24.4	25
F	500	700	1000	500	700	1000	500	700	1000

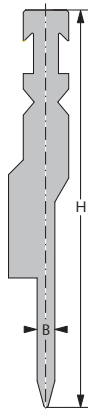

P900 and V900



Material thickness mm	Required press force t/m	C mm	Required press force t/m	D mm
0.6	9	3.0	32	1.2
0.8	13	3.0	34	1.6
1.0	15	3.5	36	2.0
1.2	18	3.5	46	2.4
1.6	24	3.5	48	3.2
2.0	42	4.5	52	4.0

L = length (mm)  
S = sectionalized (mm)  
Z = width (mm)  
R = radius (mm)  
H = Height (mm)  
B = nose width (mm)  
W = die opening (mm)  
G = weight (kg/m)  
F = max. permissible load (kN/m)

## Hemming tools air bending

### Hemming tool P900 (upper tool)

Mod.	B mm	Z	L mm	Part number
P900.RFA.06	6	14	515	65206.0900.5013
P900.RFA.06	6	14	1030	65206.0900.3004
P900.RFA.06	6	14	1000 S	65206.0900.0010
P900.RFA.06	6	14	1100 S	65206.0900.1005
P900.RFA.08	8	13	515	65206.0900.5005
P900.RFA.08	8	13	1030	65206.0900.3002
P900.RFA.08	8	13	1000 S	65206.0900.0002
P900.RFA.08	8	13	1100 S	65206.0900.1002
P900.RFA.10	10	12	515	65206.0900.5004
P900.RFA.10	10	12	1030	65206.0900.3005
P900.RFA.10	10	12	1000 S	65206.0900.0004
P900.RFA.10	10	12	1100 S	65206.0900.1003
P900.RFA.12	12	11	515	65206.0900.5007
P900.RFA.12	12	11	1030	65206.0900.3003
P900.RFA.12	12	11	1000 S	65206.0900.0003
P900.RFA.12	12	11	1100 S	65206.0900.1004

Loading capacity of the tools (bending forces) P900 + V900:

Pre bending step: 25 t/m

Hemming step: 50 t/m

B=6 mm -> for sheet thickness up to 1,0 mm

B=8 mm -> for sheet thickness up to 1,5 mm

B=10 mm -> for sheet thickness up to 2,0 mm

B=12 mm -> for sheet thickness up to 2,3 mm

## Hemming tools air bending

### Hemming tool V900 (bottom tool)

V900

$L = 515 / 1030$      $S = 1000 / 1100$

V900				
H	85			
W	6	8	10	12
G	36.5	37	38	39
F	500			

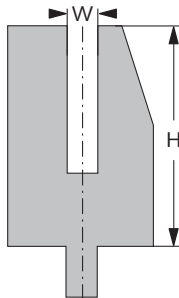

### P900 and V900

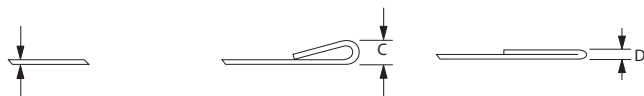

Material thickness mm	Required press force t/m	C mm	Required press force t/m	D mm
0.6	9	3.0	32	1.2
0.8	13	3.0	34	1.6
1.0	15	3.5	36	2.0
1.2	18	3.5	46	2.4
1.6	24	3.5	48	3.2
2.0	42	4.5	52	4.0

L = length (mm)  
S = sectionalized (mm)  
Z = width (mm)  
R = radius (mm)  
H = high (mm)  
B = nose width (mm)  
W = die opening (mm)  
G = weight (kg/m)  
F = max. permissible load (kN/m)

## Hemming tools air bending

### Hemming tool V900 (bottom tool)

Mod.	W mm	R mm	L mm	Part number
V900.06	6	1	515	64201.0900.5010
V900.06	6	1	1030	64201.0900.3007
V900.06	6	1	1000 S	64201.0900.0006
V900.06	6	1	1100 S	64201.0900.1004
V900.08	8	1	515	64201.0900.5005
V900.08	8	1	1030	64201.0900.3003
V900.08	8	1	1000 S	64201.0900.0002
V900.08	8	1	1100 S	64201.0900.1002
V900.10	10	1	515	64201.0900.5004
V900.10	10	1	1030	64201.0900.3004
V900.10	10	1	1000 S	64201.0900.0004
V900.10	10	1	1100 S	64201.0900.1003
V900.12	12	1	515	64201.0900.5007
V900.12	12	1	1030	64201.0900.3006
V900.12	12	1	1000 S	64201.0900.0003
V900.12	12	1	1100 S	64201.0900.1005

Loading capacity of the tools (bending forces) P900 + V900:

Pre bending step: 25 t/m

Hemming step: 50 t/m

B=6 mm -> for sheet thickness up to 1,0 mm

B=8 mm -> for sheet thickness up to 1,5 mm

B=10 mm -> for sheet thickness up to 2,0 mm

B=12 mm -> for sheet thickness up to 2,3 mm

## Upper tools Xcel / Xact

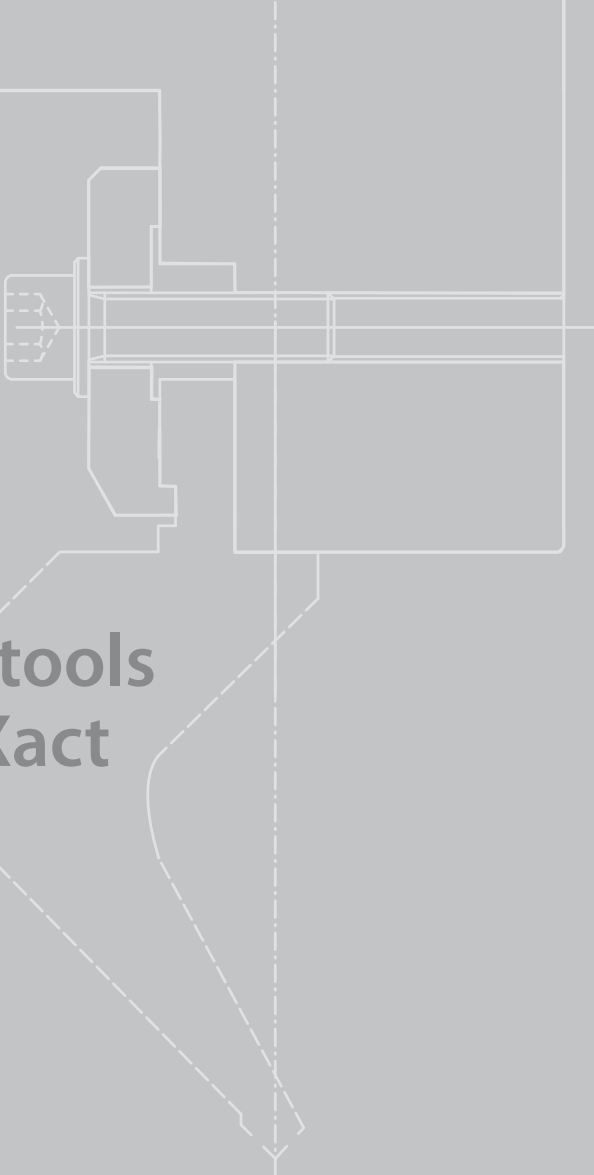

## Upper tools Xcel / Xact

### Recommendation starterkit Xcel

Bend length	Part number	Designation	Pieces	Unit
1600 mm	65035.1012.4003	Punch 1012/35° R=0,8 L=835 EURO-B	1	piece
	65035.1012.3003	Punch 1012/35° R=0,8 L=835 EURO-B sect	1	piece
	65088.1014.4005	Punch 1014/88° R=0,8 L=835 EURO-B	1	piece
	65088.1014.3003	Punch 1014/88° R=0,8 L=835 EURO-B sect	1	piece
	64201.0012.507	Die V12/30° L=515	1	piece
	64201.0012.1002	Die V12/30° L=1100 sect.FSL	1	piece

### Recommendation starterkit Xact

Bend length	Part number	Designation	Pieces	Unit
3100 mm	65035.1012.4003	Punch 1012/35° R=0,8 L=835 EURO-B	3	pieces
	65035.1012.3003	Punch 1012/35° R=0,8 L=835 EURO-B sect	1	piece
	65088.1014.4005	Punch 1014/88° R=0,8 L=835 EURO-B	3	pieces
	65088.1014.3003	Punch 1014/88° R=0,8 L=835 EURO-B sect	1	piece
	64201.0016.5011	Die V16/30° L=515	4	pieces
	64201.0016.1002	Die V16/30° L=1100 sect.FSL	1	piece
4100 mm	65035.1012.4003	Punch 1012/35° R=0,8 L=835 EURO-B	4	pieces
	65035.1012.3003	Punch 1012/35° R=0,8 L=835 EURO-B sect	1	piece
	65088.1014.4005	Punch 1014/88° R=0,8 L=835 EURO-B	4	pieces
	65088.1014.3003	Punch 1014/88° R=0,8 L=835 EURO-B sect	1	piece
	64201.0016.5011	Die V16/30° L=515	6	pieces
	64201.0016.1002	Die V16/30° L=1100 sect.FSL	1	piece



## Recommendation upper tools

### Clamping Euro B

Euro B mechanical  
(Standard Xact)

Euro B hydraulic  
(Optional Xact)

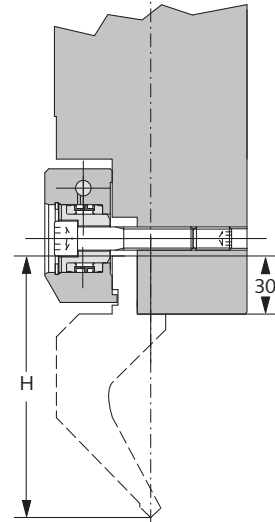
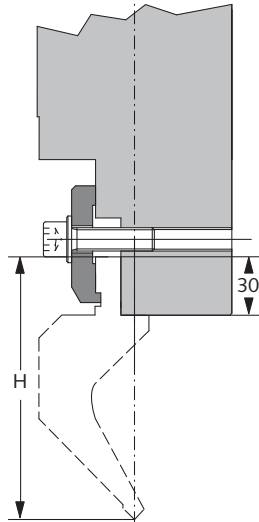

 ≤ 800 kN/m

 sideways insertion

 shoulder supported

 mechanical and hydraulic

## Recommendation upper tools

### Upper tools segmentation

Segmentation 835 mm  
(10 / 15 / 20 / 40 / 50 / (2 x 100) / 200 / 300)

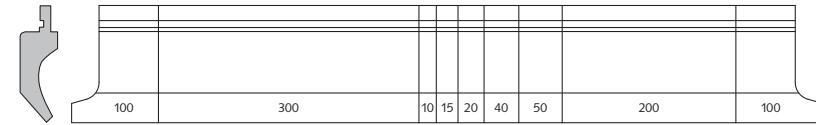

Special segmentation available on request.

## 10.10

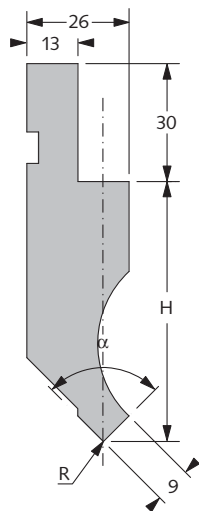

[R] Radius (mm) 0.2/0.8/3

Nose Angle 88°

[H] Height (mm) 67/66.7/65.7

[B] Width (mm) 26

C45

54 - 56 HRC

Fmax = 600 kN/m

Sideways insertion

Shoulder supported

13.5 kg/m

Euro B

21.0 mm

Ex stock / 24 h

BOS No. IA00041/IA00017/IA00037

Standard length	Part number
415 mm / 835 mm R = 0.2	65088.1010.4008 / 65088.1010.4007
835 mm sect. R = 0.2	65088.1010.3003
415 mm / 835 mm R = 0.8	65088.1010.4002 / 65088.1010.4001
835 mm sect. R = 0.8	65088.1010.3001
415 mm / 835 mm R = 3	65088.1010.4004 / 65088.1010.4003
835 mm sect. R = 3	65088.1010.3002

## 10.116

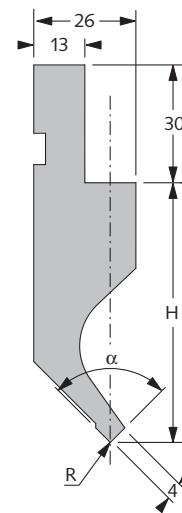

[R] Radius (mm) 0.2

Nose angle 88°/90°

[H] Height (mm) 67

[B] Width (mm) 26

C45

54 - 56 HRC

Fmax = 200 kN/m

Sideways insertion

Shoulder supported

12 kg/m

Euro B

21.0 mm

Ex Stock / 24 h

BOS No. IA00120/IA00122

Standard length	Part number
415 mm 88°	65088.1116.4001
835 mm 88°	65088.1116.4002
835 mm sect. 88°	65088.1116.3001
415 mm 90°	65090.1116.4001
835 mm 90°	65090.1116.4002
835 mm sect. 90°	65090.1116.3001

## 10.14

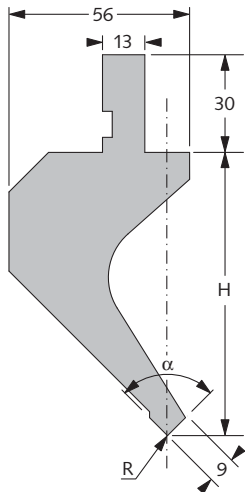

[R] Radius (mm) 0.2/0.8/3

Nose angle 88°

[H] Height (mm) 90/89.7/88.7

[B] Width (mm) 56

C45

54 - 56 HRC

 F<sub>max</sub> = 500 kN/m

Sideways insertion

Shoulder supported

25 kg/m

Euro B

37.1 mm

Ex stock / 24 h

BOS No. IA00069/IA00009/IA00148

Standard length	Part number
415 mm / 835 mm R = 0.2	65088.1014.4009 / 65088.1014.4010
835 mm sect. R = 0.2	65088.1044.3005
415 mm / 835 mm R = 0.8	65088.1014.4006 / 65088.1014.4005
835 mm sect. R = 0.8	65088.1014.3003
415 mm / 835 mm R = 3	65088.1014.4004 / 65088.1014.4003
835 mm sect. R = 3	65088.1014.3002

## 10.15

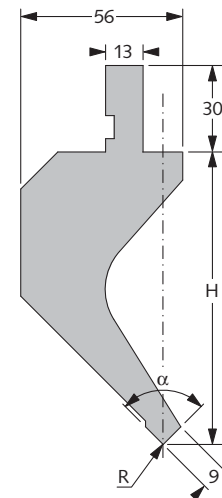

[R] Radius (mm) 0.2/0.8/3

Nose angle 88°

[H] Height (mm) 105/104.7/103.7

[B] Width (mm) 56

C45

54 - 56 HRC

 F<sub>max</sub> = 500 kN/m

Sideways insertion

Shoulder supported

26.7 kg/m

Euro B

47.6 mm

Ex stock / 24 h

BOS No. IA00082/IA00033/IA00080

Standard length	Part number
415 mm / 835 mm R = 0.2	65088.1015.4013 / 65088.1015.4014
835 mm sect. R = 0.2	65088.1015.3006
415 mm / 835 mm R = 0.8	65088.1015.4004 / 65088.1015.4003
835 mm sect. R = 0.8	65088.1015.3002
415 mm / 835 mm R = 3	65088.1015.4006 / 65088.1015.4005
835 mm sect. R = 3	65088.1015.3003

## 10.047

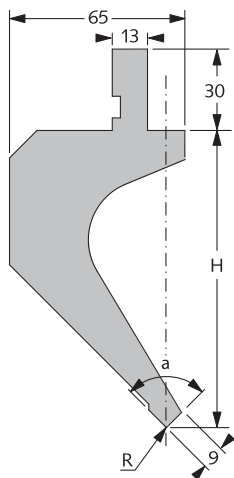

[R] Radius (mm) 0.2/0.8

Nose angle 88°

[H] Height (mm) 120/119.7

[B] Width (mm) 65

C45

54 - 56 HRC

F<sub>max</sub> = 500 kN/m

Sideways insertion

Shoulder supported

31.5 kg/m

Euro B

58.8 mm

Ex stock / 24 h

BOS No. IA00104/IA00105

**Standard length****Part number**

415 mm / 835 mm R = 0.2	65088.1047.4004 / 65088.1047.4001
835 mm sect. R = 0.2	65088.1047.3001
415 mm / 835 mm R = 0.8	65088.1047.4005 / 65088.1047.4006
835 mm sect. R = 0.8	65088.1047.3003

## 10.048

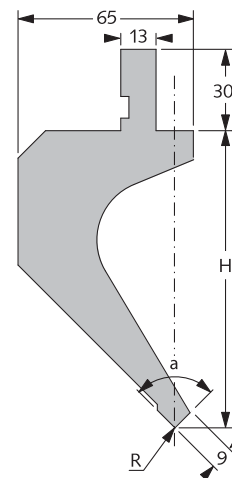

[R] Radius (mm) 0.2

Nose angle 90°

[H] Height (mm) 120

[B] width (mm) 65

C45

54 - 56 HRC

F<sub>max</sub> = 500 kN/m

Sideways insertion

Shoulder supported

31.5 kg/m

Euro B

58.8 mm

Ex stock / 24 h

BOS No. IA00100

**Standard length****Part number**

415 mm / 835 mm R = 0.2	65090.1048.4001 / 65090.1048.4002
835 mm sect. R = 0.2	65090.1048.3001
415 mm / 835 mm R = 0.8	65090.1048.4003 / 65090.1048.4004
835 mm sect. R = 0.8	65090.1048.3002

## 10.109

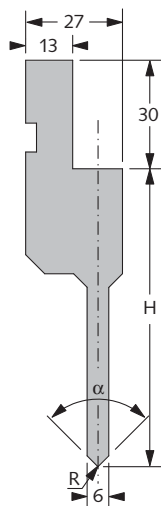

[R] Radius (mm) 0.2

Nose angle 88°/90°

[H] Height (mm) 95

[B] Width (mm) 27



C45



54 - 56 HRC

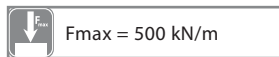

Fmax = 500 kN/m

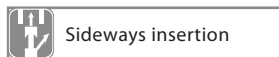

Sideways insertion

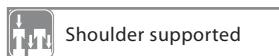

Shoulder supported



11.5 kg/m



Euro B



42.0 mm



Ex stock / 24 h



IA00443

Standard length	Part number
415 mm 88°	65088.1109.4002
835 mm 88°	65088.1109.4001
835 mm sect. 88°	65088.1109.3010
415 mm 90°	65090.1109.4001
835 mm 90°	65090.1109.4002
835 mm sect. 90°	65090.1109.3001

## 10.18

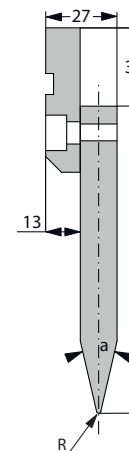

[R] Radius (mm) 0.8

Nose angle 26°

[H] Height (mm) 117

[B] Width (mm) 27



C45



54 - 56 HRC

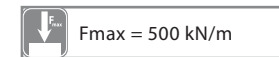

Fmax = 500 kN/m

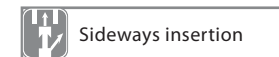

Sideways insertion

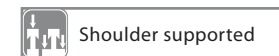

Shoulder supported



16 kg/m



Euro B

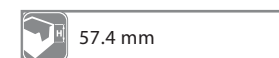

57.4 mm



Ex stock / 24 h

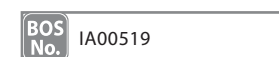

IA00519

Standard length	Part number
415 mm R = 0.8	65026.1018.4002
835 mm R = 0.8	65026.1018.4001
835 mm sect. R = 0.8	65026.1018.3001

## 10.12

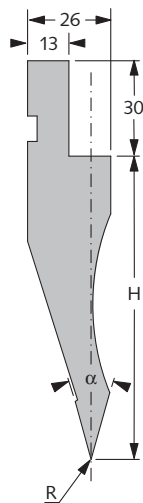

[R] Radius (mm) 0.8

Nose angle 35°/30°

[H] Height (mm) 90

[B] width (mm) 26



C45



54 - 56 HRC

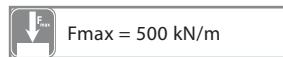

Fmax = 500 kN/m

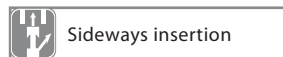

Sideways insertion

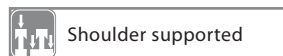

Shoulder supported

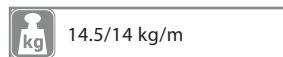

14.5/14 kg/m

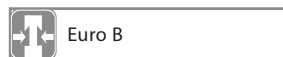

Euro B

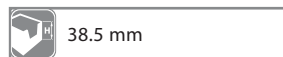

38.5 mm

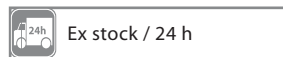

Ex stock / 24 h



BOS No. IA00001/IA00050

Standard length	Part number
415 mm 35°	65035.1012.4004
835 mm 35°	65035.1012.4003
835 mm sect. 35°	65035.1012.3003
415 mm 30°	65030.1012.4009
835 mm 30°	65030.1012.4005
835 mm sect. 30°	65030.1012.3003

## 10.13/35°

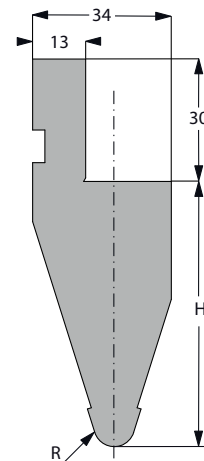

[R] Radius (mm) 5

Nose angle 35°

[H] Height (mm) 65

[B] width (mm) 34



C45



54 - 56 HRC

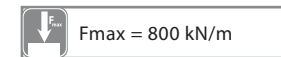

Fmax = 800 kN/m

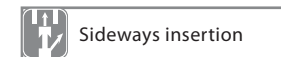

Sideways insertion

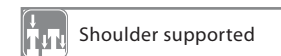

Shoulder supported



15 kg/m

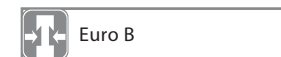

Euro B



21.0 mm



Ex stock / 24 h



BOS No. IA00010

Standard length	Part number
415 mm	65035.1013.4002
835 mm	65035.1013.4001
835 mm sect.	65035.1013.3001

## 10.13/60°

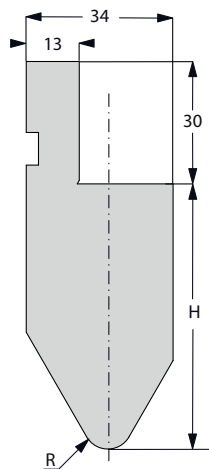

[R] Radius (mm) 6

Nose angle 60°

[H] Height (mm) 65

[B] width (mm) 36

 C45

 54 - 56 HRC

 F<sub>max</sub> = 800 kN/m

 Sideways insertion

 Shoulder supported

 16 kg/m

 Euro B

 21.0 mm

 Ex stock / 24 h

**BOS No.** IA00016

Standard length	Part number
415 mm	65060.1013.4001
835 mm	65060.1013.4003
835 mm sect.	65060.1013.3001

## Bottom tools Xcel / Xact

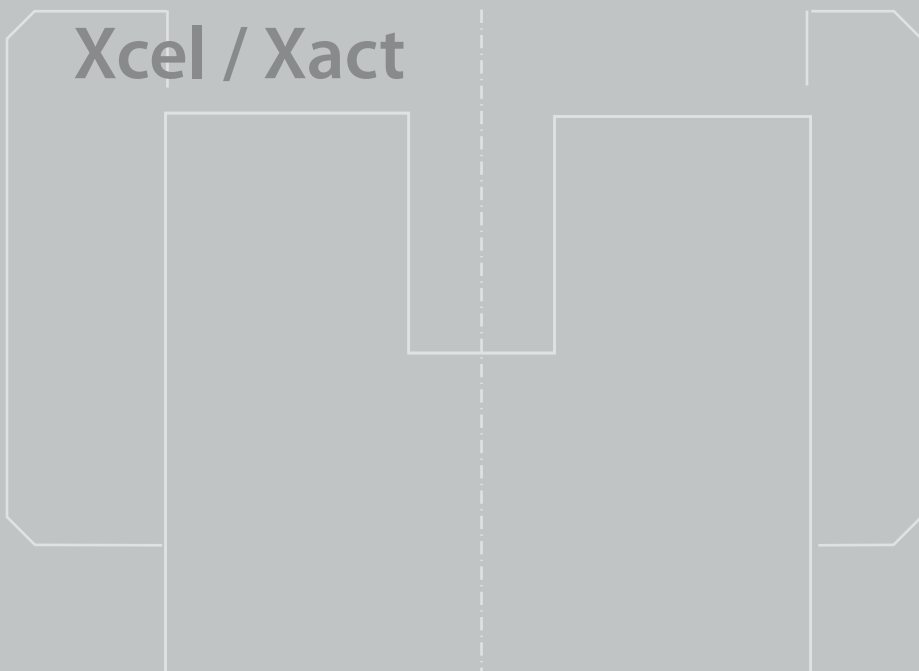

## Bottom tools Xcel / Xact

### Recommendation starterkit Xcel

Bend length	Part number	Designation	Pieces	Unit
1600 mm	65035.1012.4003	Punch 1012/35° R=0,8 L=835 EURO-B	1	piece
	65035.1012.3003	Punch 1012/35° R0,8 L=835 EURO-B sect	1	piece
	65088.1014.4005	Punch 1014/88° R=0,8 L=835 EURO-B	1	piece
	65088.1014.3003	Punch 1014/88° R0,8 L=835 EURO-B sect	1	piece
	64201.0012.507	Die V12/30° L=515	1	piece
	64201.0012.1002	Die V12/30° L=1100 sect.FSL	1	piece

### Recommendation starterkit Xact

Bend length	Part number	Designation	Pieces	Unit
3100 mm	65035.1012.4003	Punch 1012/35° R=0,8 L=835 EURO-B	3	pieces
	65035.1012.3003	Punch 1012/35° R0,8 L=835 EURO-B sect	1	piece
	65088.1014.4005	Punch 1014/88° R=0,8 L=835 EURO-B	3	pieces
	65088.1014.3003	Punch 1014/88° R0,8 L=835 EURO-B sect	1	piece
	64201.0016.5011	Die V16/30° L=515	4	pieces
	64201.0016.1002	Die V16/30° L=1100 sect.FSL	1	piece
4100 mm	65035.1012.4003	Punch 1012/35° R=0,8 L=835 EURO-B	4	pieces
	65035.1012.3003	Punch 1012/35° R0,8 L=835 EURO-B sect	1	piece
	65088.1014.4005	Punch 1014/88° R=0,8 L=835 EURO-B	4	pieces
	65088.1014.3003	Punch 1014/88° R0,8 L=835 EURO-B sect	1	piece
	64201.0016.5011	Die V16/30° L=515	6	pieces
	64201.0016.1002	Die V16/30° L=1100 sect.FSL	1	piece



## Recommendation bottom tools

Table T21

Table T21  
(Standard Xact)

Can accept both Xpert single vee lower dies and Euro B lower dies.

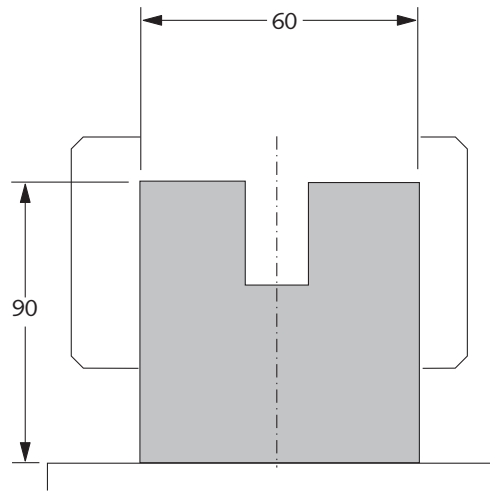

## Recommendation bottom tools

### Segmentation

Segmentation 835 mm  
(10 / 15 / 20 / 40 / 50 / 2 x 100 / 200 / 300)

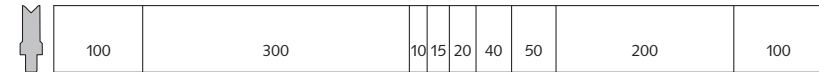

Special segmentation available on request.

## V 6 Type 20.41/88/90

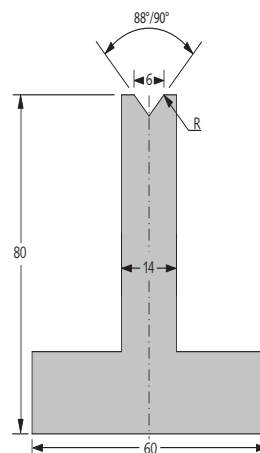

[R] Radius (mm) 0.5/0.4

V - Angle 88°/90°

[H] Height (mm) 80

[B] Width (mm) 60

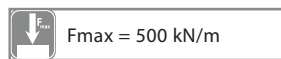
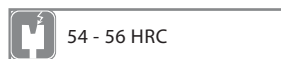

Standard length	Part number
415 mm 88°	64060.2041.0004
835 mm 88°	64088.2041.0002
835 mm sect. 88°	64088.2041.0003
415 mm 90°	64090.2041.1001
835 mm 90°	64090.2041.1002
835 mm sect. 90°	64090.2041.0001

## V 6 Type 20.41/60

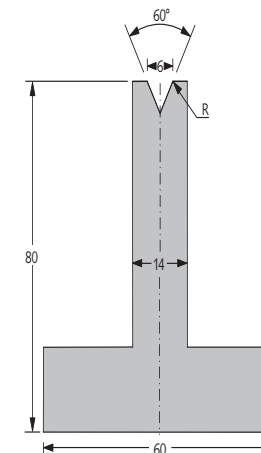

[R] Radius (mm) 0.5

V - Angle 60°

[H] Height (mm) 80

[B] Width (mm) 60

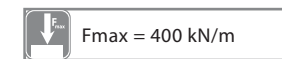

Standard length	Part number
415 mm 60°	64060.2041.1003
835 mm 60°	64060.2041.1004
835 mm sect. 60°	64060.2041.0001

## V 6 Type 20.41/35/30

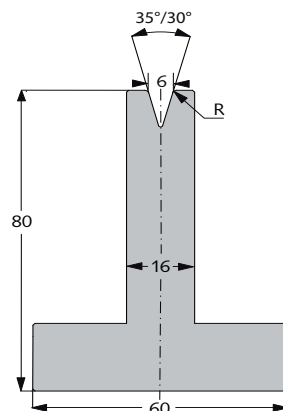

[R] Radius (mm)	1
V - Angle	35°/30°
[H] Height (mm)	80
[B] Width (mm)	60

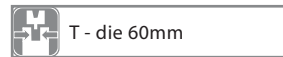
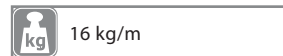
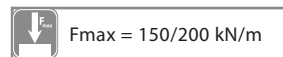
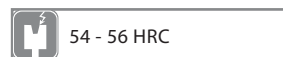

Standard length	Part number
415 mm 35°	64035.2041.1002
835 mm 35°	64035.2041.1003
835 mm sect. 35°	64035.2041.0001
415 mm 30°	64030.2041.1002
835 mm 30°	64030.2041.1001
835 mm sect. 30°	64030.2041.0001

## V 8 Type 20.42/88/90

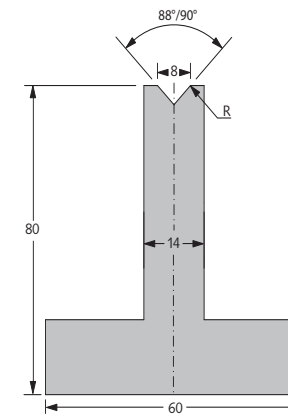
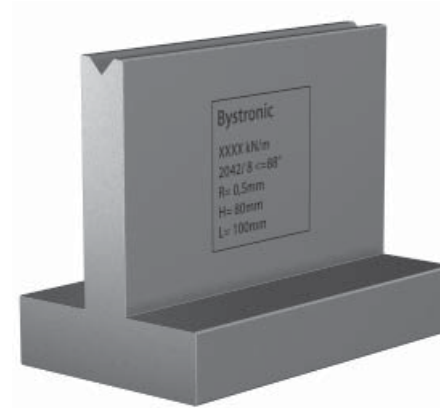

[R] Radius (mm)	0.5
V - Angle	88°/90°
[H] Height (mm)	80
[B] Width (mm)	60

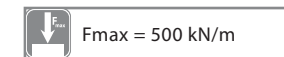

Standard length	Part number
415 mm 88°	64088.2042.1002
835 mm 88°	64088.2042.1003
835 mm sect. 88°	64088.2042.0002
415 mm 90°	64090.2042.1001
835 mm 90°	64090.2042.1002
835 mm sect. 90°	64090.2042.0001

## V 8 Type 20.42/60

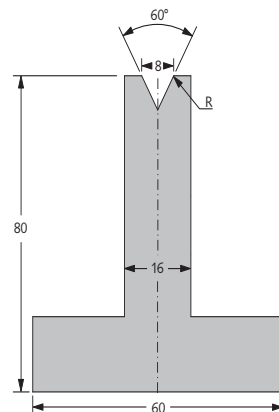
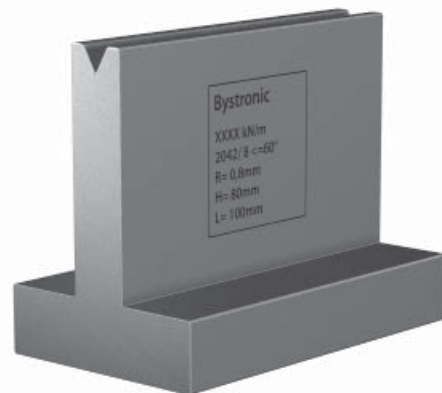

[R] Radius (mm) 0.8

V - Angle 60°

[H] Height (mm) 80

[B] Width (mm) 60

Standard length	Part number
415 mm 60°	64060.2042.1004
835 mm 60°	64060.2042.1003
835 mm sect. 60°	64060.2042.0001

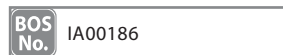
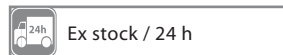
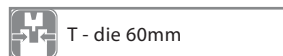
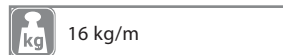
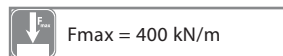

## V 8 Type 20.42/35/30

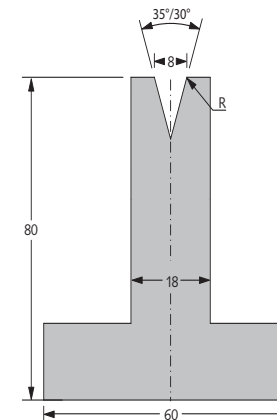
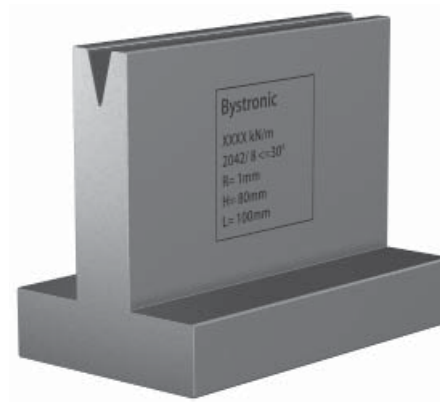

[R] Radius (mm) 1

V - Angle 35°/30°

[H] Height (mm) 80

[B] Width (mm) 60

Standard length	Part number
415 mm 35°	64035.2042.1007
835 mm 35°	64035.2042.1006
835 mm sect. 35°	64035.2042.0002
415 mm 30°	64030.2042.1001
835 mm 30°	64030.2042.1002
835 mm sect. 30°	64030.2042.0001

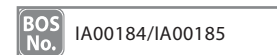
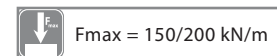

## V 10 Type 20.43/88/90

## V 10 Type 20.43/60

136

137

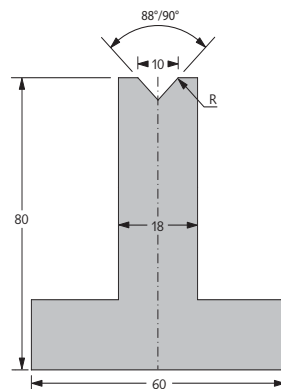
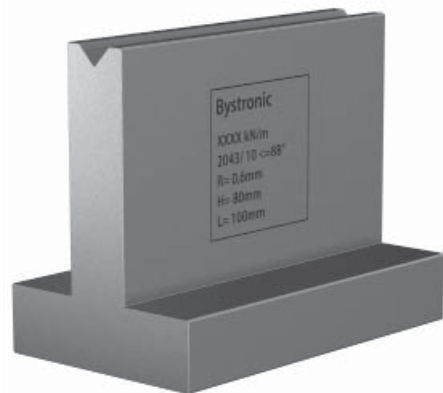

[R] Radius (mm) 0.6

V - Angle 88°/90°

[H] Height (mm) 80

[B] Width (mm) 60



C45

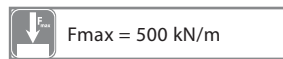

54 - 56 HRC

F<sub>max</sub> = 500 kN/m

17 kg/m



T - die 60mm



Ex stock / 24 h



IA00192/IA00193

Standard length	Part number
415 mm 88°	64088.2043.1002
835 mm 88°	64088.2043.1001
835 mm sect. 88°	64088.2043.0001
415 mm 90°	64090.2043.1001
835 mm 90°	64090.2043.1002
835 mm sect. 90°	64090.2043.0001

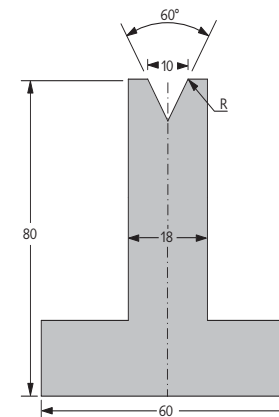

[R] Radius (mm) 1

V - Angle 60°

[H] Height (mm) 80

[B] Width (mm) 60



C45

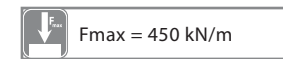

54 - 56 HRC

F<sub>max</sub> = 450 kN/m

16.8 kg/m



T - die 60mm



Ex stock / 24 h



IA00191

Standard length	Part number
415 mm 60°	64060.2043.1003
835 mm 60°	64060.2043.1001
835 mm sect. 60°	64060.2043.0001

## V 10 Type 20.43/35/30

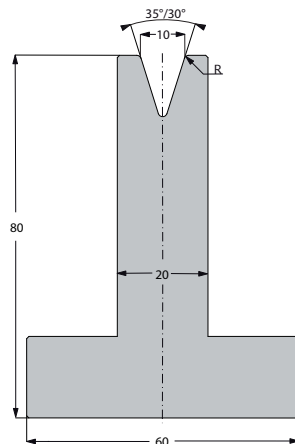
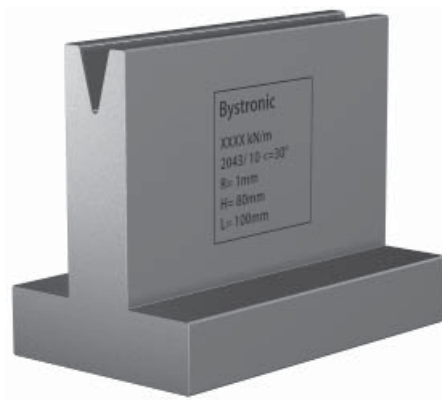

[R] Radius (mm)	1
V - Angle	35°/30°
[H] Height (mm)	80
[B] Width (mm)	60

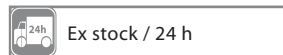
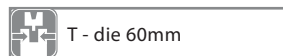
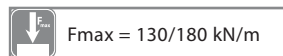

Standard length	Part number
415 mm 35°	64035.2043.1006
835 mm 35°	64035.2043.1005
835 mm sect. 35°	64035.2043.0002
415 mm 30°	64030.2043.1002
835 mm 30°	64030.2043.1001
835 mm sect. 30°	64030.2043.0001

## V 12 Type 20.44/88/90

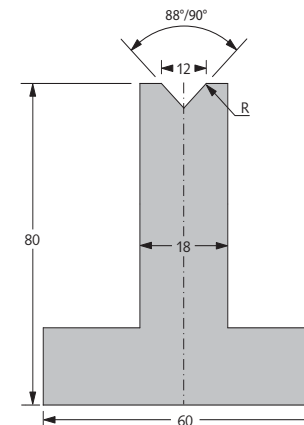
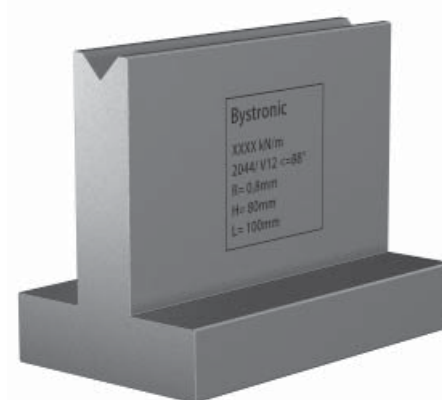

[R] Radius (mm)	0.8
V - Angle	88°/90°
[H] Height (mm)	80
[B] Width (mm)	60

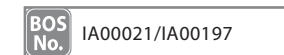
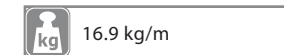
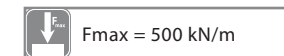
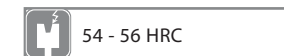

Standard length	Part number
415 mm 88°	64088.2044.1006
835 mm 88°	64088.2044.1005
835 mm sect. 88°	64088.2044.0002
415 mm 90°	64090.2044.1002
835 mm 90°	64090.2044.1001
835 mm sect. 90°	64090.2044.0001

## V 12 Type 20.44/60

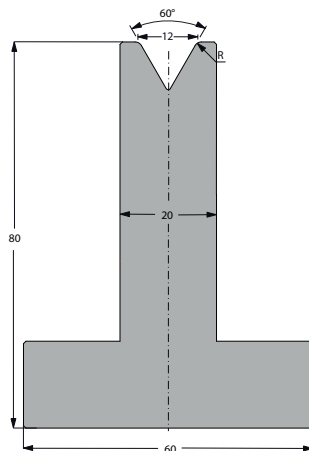

[R] Radius (mm) 1.5

V - Angle 60°

[H] Height (mm) 80

[B] Width (mm) 60

Standard length	Part number
415 mm 60°	64060.2044.1007
835 mm 60°	64060.2044.1006
835 mm sect. 60°	64060.2044.0001

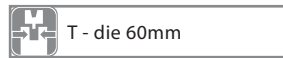
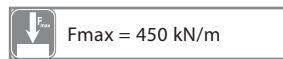

## V 12 Type 20.44/35/30

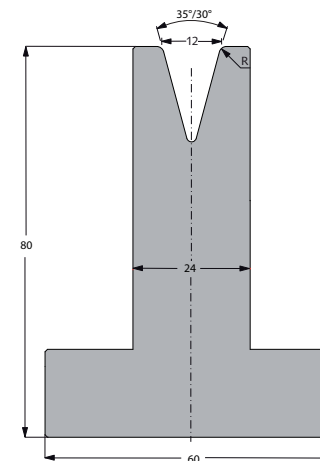
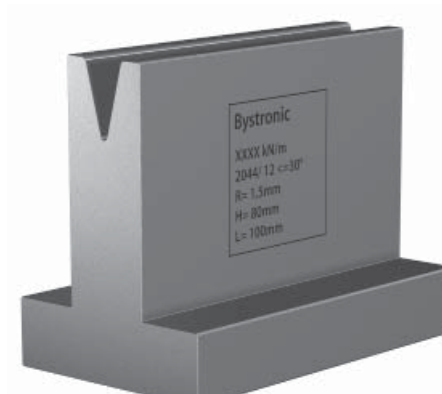

[R] Radius (mm) 1.5

V - Angle 35°/30°

[H] Height (mm) 80

[B] Width (mm) 60

Standard length	Part number
415 mm 35°	64035.2044.1007
835 mm 35°	64035.2044.1006
835 mm sect. 35°	64035.2044.0001
415 mm 30°	64030.2044.1001
835 mm 30°	64030.2044.1002
835 mm sect. 30°	64030.2044.0001

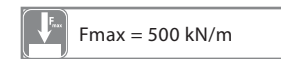

## V 16 Type 20.45/88/90

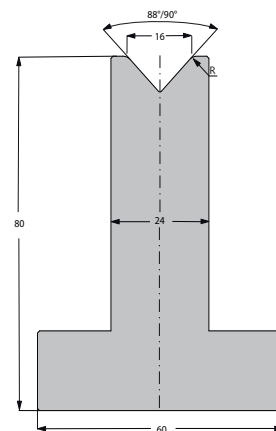
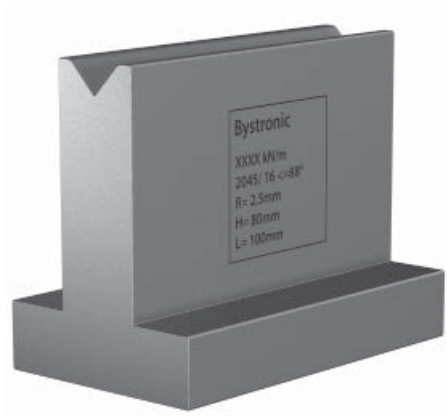

[R] Radius (mm) 2.5

V - Angle 88°/90°

[H] Height (mm) 80

[B] Width (mm) 60

Standard length	Part number
415 mm 88°	64088.2045.1002
835 mm 88°	64088.2045.1001
835 mm sect. 88°	64088.2045.0001
415 mm 90°	64090.2045.1002
835 mm 90°	64090.2045.1001
835 mm sect. 90°	64090.2045.0001

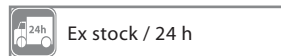
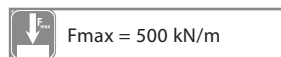
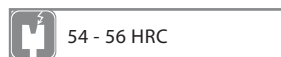

## V 16 Type 20.45/60

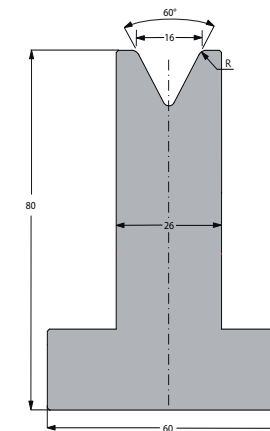

[R] Radius (mm) 2

V - Angle 60°

[H] Height (mm) 80

[B] Width (mm) 60

Standard length	Part number
415 mm 60°	64060.2045.1003
835 mm 60°	64060.2045.1002
835 mm sect. 60°	64060.2045.0001

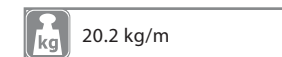
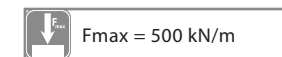



## V 16 Type 20.45/35/30

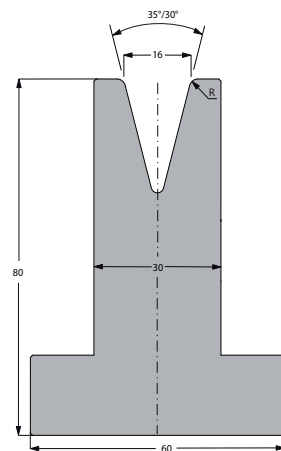
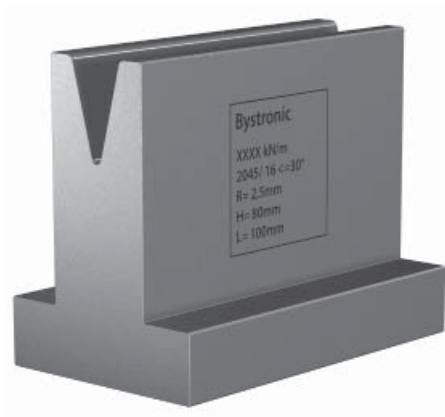

[R] Radius (mm) 2.0

V - Angle 35°/30°

[H] Height (mm) 80

[B] Width (mm) 60

Standard length	Part number
415 mm 35°	64035.2045.1004
835 mm 35°	64035.2045.1005
835 mm sect. 35°	64035.2045.0002
415 mm 30°	64030.2045.1004
835 mm 30°	64030.2045.1002
835 mm sect. 30°	64030.2045.0002

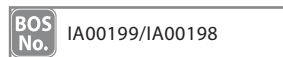
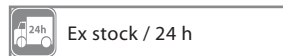
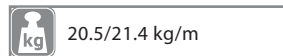
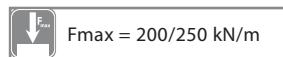
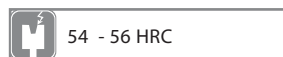

## V 20 Type 20.46/88/90

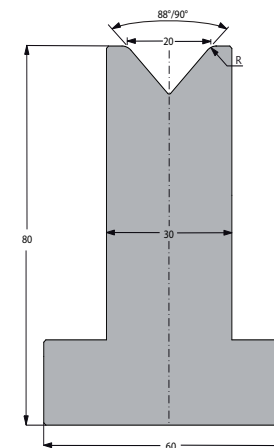
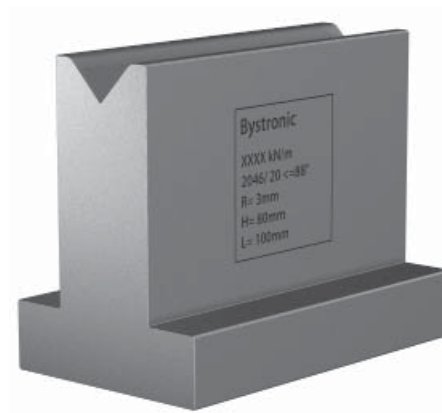

[R] Radius (mm) 3

V - Angle 88°/90°

[H] Height (mm) 80

[B] Width (mm) 60

Standard length	Part number
415 mm 88°	64088.2046.1002
835 mm 88°	64088.2046.1001
835 mm sect. 88°	64088.2046.0001
415 mm 90°	64090.2046.1002
835 mm 90°	64090.2046.1001
835 mm sect. 90°	64090.2046.0001

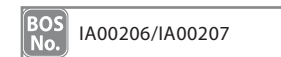
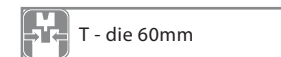
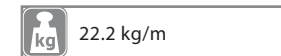
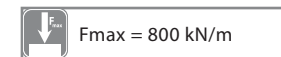

## V 20 Type 20.46/60

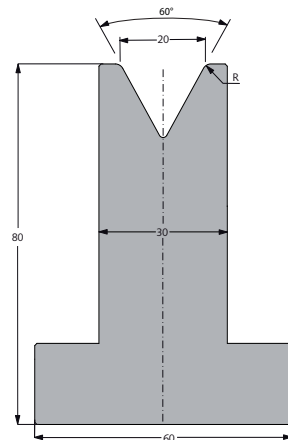
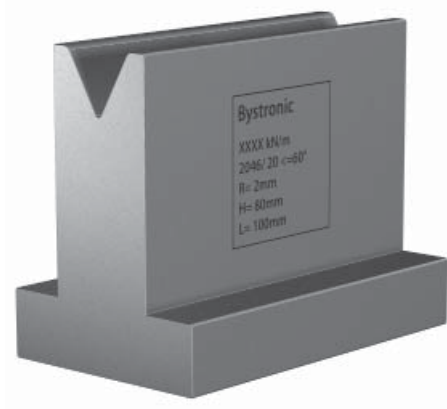

[R] Radius (mm)	2
V - Angle	60°
[H] Height (mm)	80
[B] Width (mm)	60

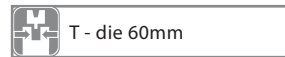
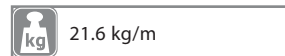
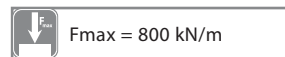

Standard length	Part number
415 mm 60°	64060.2046.1007
835 mm 60°	64060.2046.1006
835 mm sect. 60°	64060.2046.0002

## V 20 Type 20.46/35/30

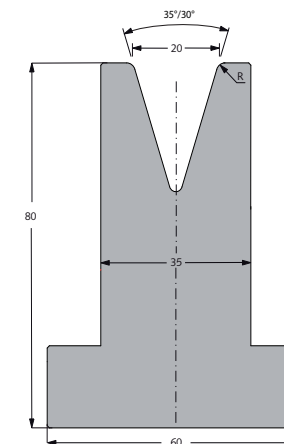

[R] Radius (mm)	1.5
V - Angle	35°/30°
[H] Height (mm)	80
[B] Width (mm)	60

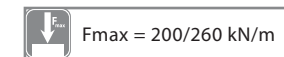
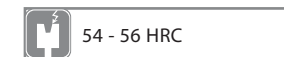

Standard length	Part number
415 mm 35°	64035.2046.4002
835 mm 35°	64035.2046.4001
835 mm sect. 35°	64035.2046.3001
415 mm 30°	64030.2046.1002
835 mm 30°	64030.2046.1001
835 mm sect. 30°	64030.2046.0001

## V 25 Type 20.47/85

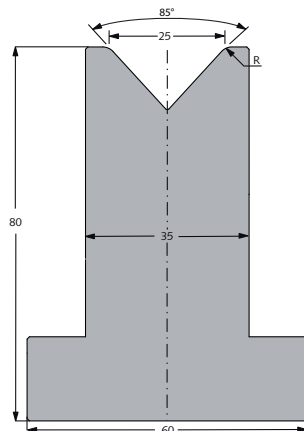
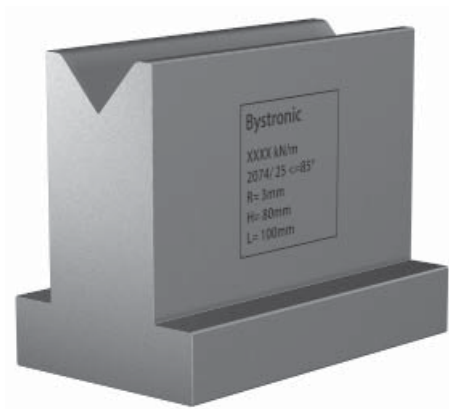

[[R] Radius (mm)	3
V - Angle	85°
[H] Height (mm)	80
[B] Width (mm)	60

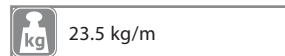
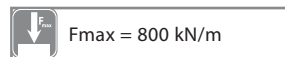

Standard length	Part number
415 mm 85°	64085.2047.1002
835 mm 85°	64085.2047.1001
835 mm sect. 85°	64085.2047.0001

## V 32 Type 20.11/85

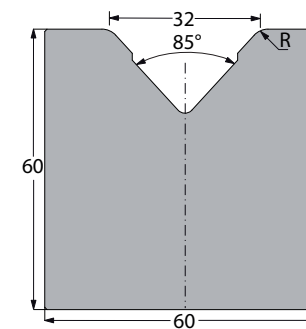

[R] Radius (mm)	4
V - Angle	85°
[H] Height (mm)	60
[B] Width (mm)	60

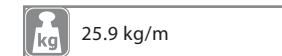
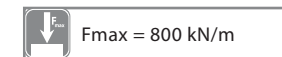
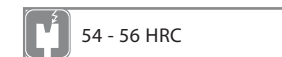

Standard length	Part number
415 mm 85°	64085.2011.1048
835 mm 85°	64085.2011.1043
835 mm sect. 85°	64085.2011.0003

## V 40 Type 20.11/85

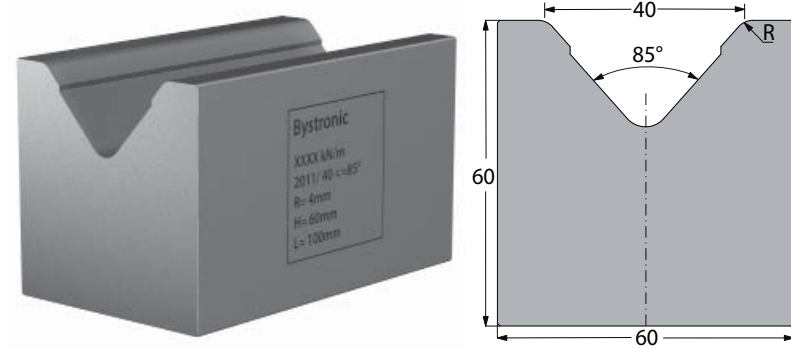

[R] Radius (mm)	4
V - Angle	85°
[H] Height (mm)	60
[B] Width (mm)	60

 C45

 54 - 56 HRC

 F<sub>max</sub> = 800 kN/m

 25.3 kg/m

 T - die 60mm

 Ex stock / 24 h

 IA00162

Standard length	Part number
415 mm 85°	64085.2011.1049
835 mm 85°	64085.2011.1035
835 mm sect. 85°	64085.2011.0005

## V 50 Type 20.11/85

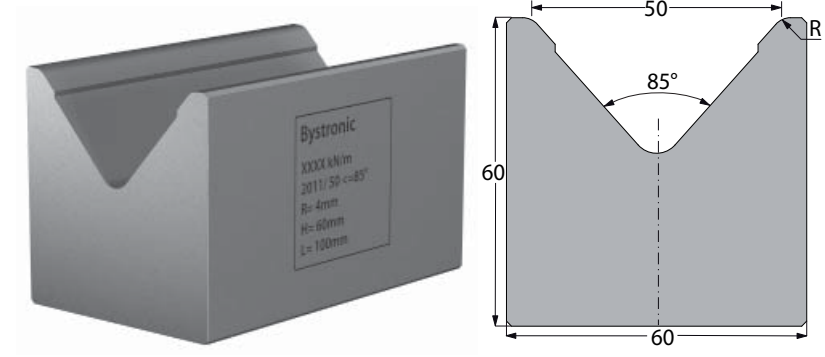

[R] Radius (mm)	4
V - Angle	85°
[H] Height (mm)	60
[B] Width (mm)	60

 C45

 54 - 56 HRC

 F<sub>max</sub> = 800 kN/m

 22.5 kg/m

 T - die 60mm

 Ex stock / 24 h

 IA00006

Standard length	Part number
415 mm 85°	64085.2011.1037
835 mm 85°	64085.2011.1038
835 mm sect. 85°	64085.2011.0004

## V 63 Type 20.11/85

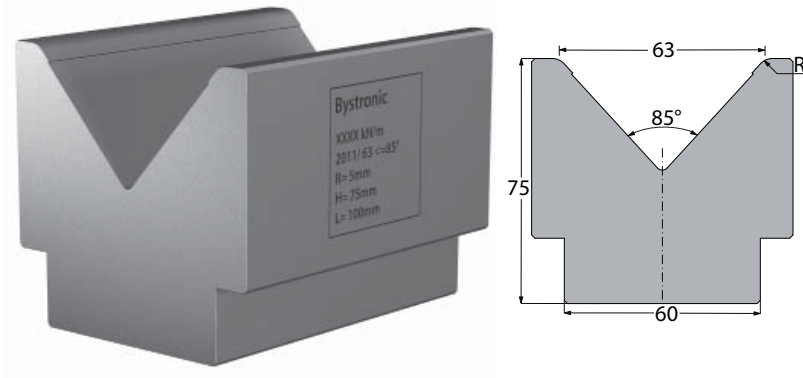

[R] Radius (mm)	5
V - Angle	85°
[H] Height (mm)	75
[B] Width (mm)	80

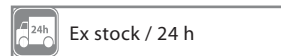
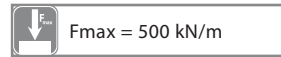

Standard length	Part number
415 mm 85°	64085.2011.1041
835 mm 85°	64085.2011.1040
835 mm sect. 85°	64085.2011.0006

## V 80 Type 20.11/85

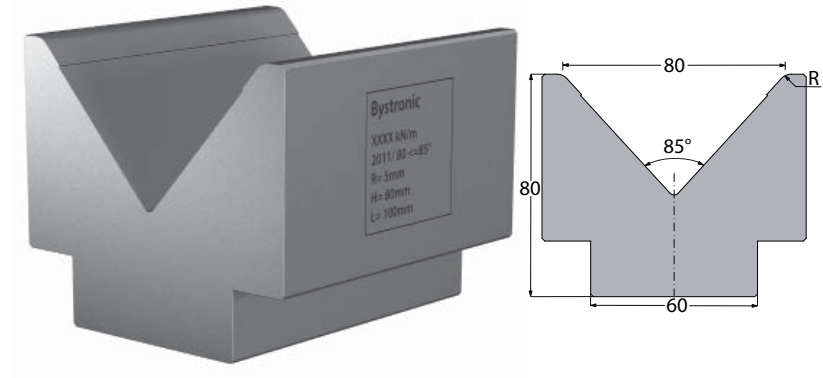

[R] Radius (mm)	5
V - Angle	85°
[H] Height (mm)	80
[B] Width (mm)	95

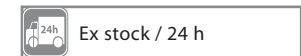

Standard length	Part number
415 mm 85°	64085.2011.1039
835 mm 85°	64085.2011.1036
835 mm sect. 85°	64085.2011.0007

## V 100 Type 20.11/85

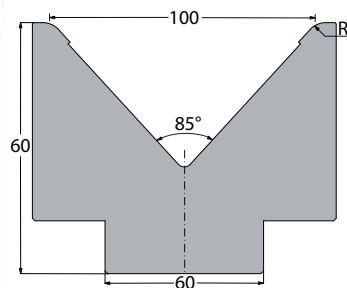

[R] Radius (mm)	8
V - Angle	85°
[H] Height (mm)	95
[B] Width (mm)	115

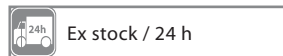
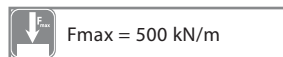
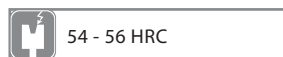

Standard length	Part number
415 mm 85°	64085.2011.1044
835 mm 85°	64085.2011.1042
835 mm sect. 85°	64085.2011.0008

## V 125 Type 20.11/85

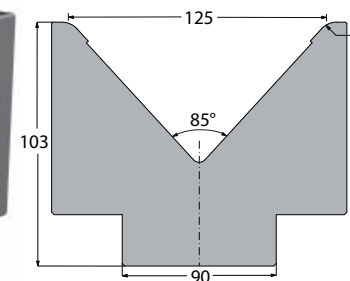

[R] Radius (mm)	15
V - Angle	80°
[H] Height (mm)	103
[B] Width (mm)	154

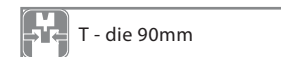
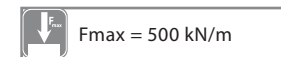
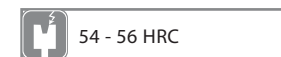

Standard length	Part number
415 mm 85°	64085.2011.1050
835 mm 85°	64085.2011.1047
835 mm sect. 85°	64085.2011.0009

## V 160 Type 20.11/85

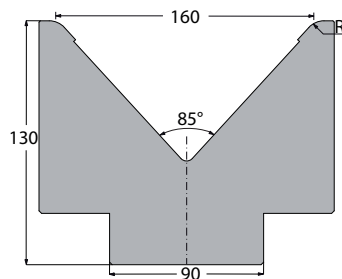

[R] Radius (mm)	15
V - Angle	80°
[H] Height (mm)	130
[B] Width (mm)	185

Standard length	Part number
415 mm 85°	64085.2011.1051
835 mm 85°	64085.2011.1052
835 mm sect. 85°	64085.2011.0010

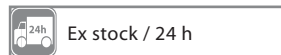
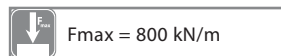

## Multi-V 16/22/35/50 Type 20.09

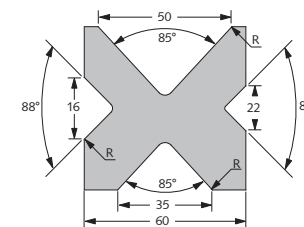
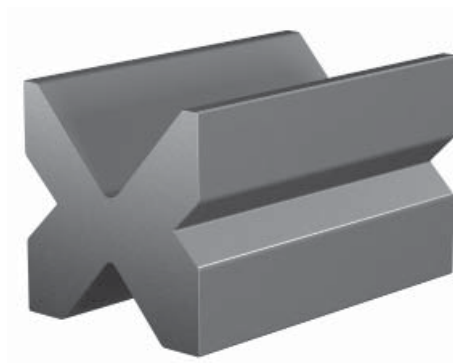

[R] Radius (mm)	2
V - Angle	85°/88°
[H] Height (mm)	
[B] Width (mm)	60

Standard length	Part number
415 mm	64000.2009.1005
835 mm	64000.2009.1010
835 mm sect.	64000.2009.0003

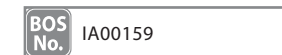
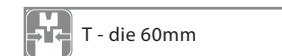
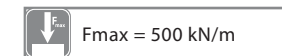
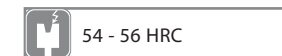

## Hemming tools V 10 Type 30.01/26/35

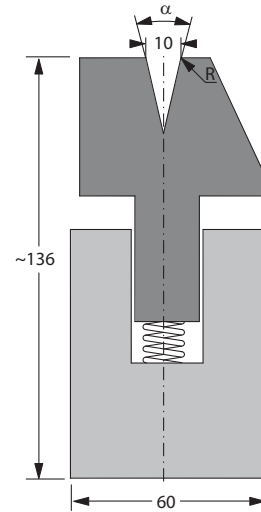

[R] Radius (mm)	1
V - Angle	26°/35°
[H] Height (mm)	~136
[B] Width (mm)	60

Standard length	Part number
415 mm 26°	64026.3001.1005
835 mm 26°	64026.3001.1006
sekt. 835 mm 26°	64026.3001.0001
415 mm 35°	64035.3001.1007
835 mm 35°	64035.3001.1005
sekt. 835 mm 35°	64035.3001.0001



## Hemming tool V 12 Type 30.01/26/35

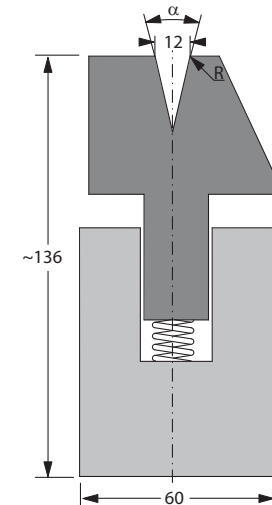
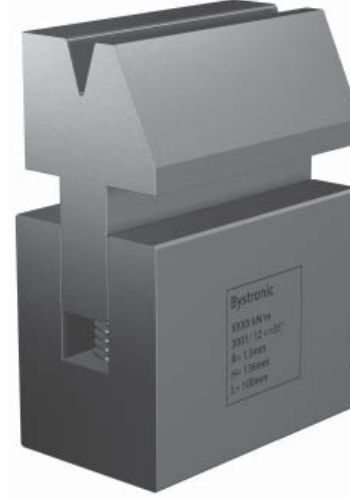

[R] Radius (mm)	1.5
V - Angle	26°/35°
[H] Height (mm)	~136
[B] Width (mm)	60

Standard length	Part number
415 mm 26°	64026.3001.1001
835 mm 26°	64026.3001.1007
sekt. 835 mm 26°	64026.3001.0002
415 mm 35°	64035.3001.1004
835 mm 35°	64035.3001.1003
sekt. 835 mm 35°	64035.3001.1003

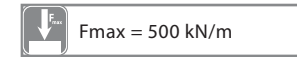



## Upper tools 3-point-bending

### Recommendation starterkit Hämmerle 3P

Bend length	Part number	Description	Piece	Unit
2100 mm	B8-10.0001.1	Punch + holder 11.028.00/21.002.00/100	17	pieces
	B8-10.0002.1	Punch + holder 11.028.00/21.002.00/200	2	pieces
	B8-10.0646	Die kpl.GS/Fld. 31.012.00/WL100	6	pieces
	B8-10.0647	Die kpl.GS/Fld. 31.012.00/WL500	3	pieces
3100 mm	B8-10.0001.1	Punch + holder 11.028.00/21.002.00/100	27	pieces
	B8-10.0002.1	Punch + holder 11.028.00/21.002.00/200	2	pieces
	B8-10.0646	Die kpl.GS/Fld. 31.012.00/WL100	6	pieces
	B8-10.0647	Die kpl.GS/Fld. 31.012.00/WL500	5	pieces
4100 mm	B8-10.0001.1	Punch + holder 11.028.00/21.002.00/100	37	pieces
	B8-10.0002.1	Punch + holder 11.028.00/21.002.00/200	2	pieces
	B8-10.0646	Die kpl.GS/Fld. 31.012.00/WL100	6	pieces
	B8-10.0647	Die kpl.GS/Fld. 31.012.00/WL500	7	pieces

## Upper tools 3-point-bending



## Calculation basics 3-point-bending

### Pressing force table

Ri (mm)	1	1.2	1.2	1.4	1.6	2	2.2
B (mm)	4	5.5	5.5	6.5	8	9	10
Die	31.005.00	31.006.00	31.007.00	31.007.20	31.010.20	31.012.00	31.013.00
V (mm)	5.0	6.0	7.0	7.5	10.9	11.5	12
t (mm)	Approx. capacity required in kN/m for mild steel plates with a tensile strength of Rm = 450 N/mm <sup>2</sup>						
0.5	29	24					
0.8	75	62	53	50	34		
1.0	117	97	84	78	54	51	49
1.25		152	131	122	84	79	76
1.5			188	175	121	114	110
2.0					215	203	195
2.5					335	318	305
3.0						458	439
3.5							
4.0							
5.0							
6.0							
7.0							
8.0							
10.0							
12.0							

$F = 450 \times \frac{t^2}{V} \times f = \dots\dots \text{kN/m}$ [t (mm), V (mm)]							
Factor f	M.S.	1,3	S.S. 1,66	Alu 0,5			

Ri = approx. inner radius  
 B = smallest flange for 90° bends  
 V = die opening  
 t = material thickness

## Calculation basics 3-point-bending

### Pressing force table

2.7	3	3.9	4.1	6	9.5	15.5	18
12.5	16	19.5	23.5	30	45.5	70	85
31.016.00	31.021.00	31.024.00	31.032.10	31.040.10	31.060.00	31.090.00	31.110.00
16	21	25.6	32.1	39.2	60	90	110
Approx. capacity required in kN/m for mild steel plates with a tensile strength of Rm = 450 N/mm <sup>2</sup>							
82							
146	111	91					
229	174	143	114				
329	251	206	164				
448	341	280	223	183			
585	446	366	292	239	156		
		571	456	373	243	166	
			656	537	351	239	
				731	478	325	
					624	424	335
					975	663	523
						955	753

For Stainless Steel: Use next bigger size of bottom tool	
--	--

Empirical rule:  
 For air bending the inner radius Ri is approx. 16% of the die opening V. The values Ri and B are valid for 90° bends.

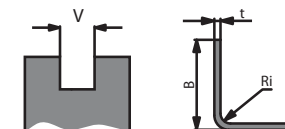

3P - bending

3P - bending

### Calculation basics 3-point-bending

#### Calculation of the hydrocushion - force

Calculation of the cushion-force for 1 top tool section of a length of 100 mm:

$$F_K = \frac{A_{1ST} \text{ (cm}^2\text{)} \times P_K \text{ (bar)}}{100}$$

$F_K$  = capacity of the cushion

$A_{1ST}$  = subjected surface of the hydrocushion (B x L)

$P_K$  = hydrocushion - force

Sample calculation:

Capacity of cushion  $F_K$  for 1 top tool section of 100mm length by a cushion pressure of 50 bar.

$$F_K = \frac{B \text{ (cm)} \times L \text{ (cm)} \times P_K \text{ (bar)}}{100}$$

$$\frac{50 \text{ cm}^2 \times 50 \text{ bar}}{100} = 2,5 \text{ t}$$

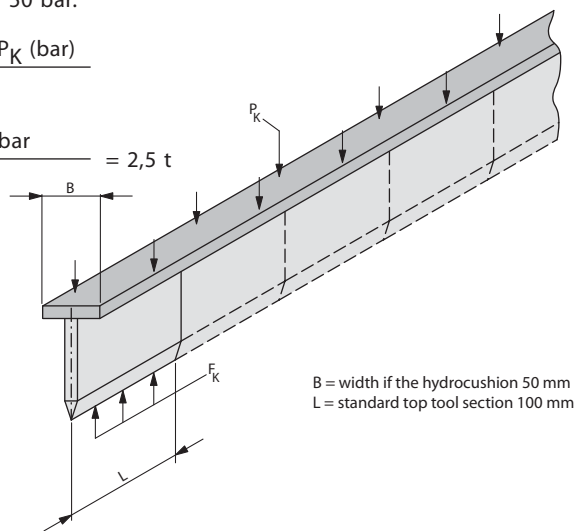

B = width of the hydrocushion 50 mm  
L = standard top tool section 100 mm

Maximum capacity of the hydrocushion 1000 kN/m (100 t/m)

### Calculation basics 3-point-bending

#### Calculation of the hydrocushion - force

Capacity of the hydrocushion  $P_K$  at a pressure of 50 bar

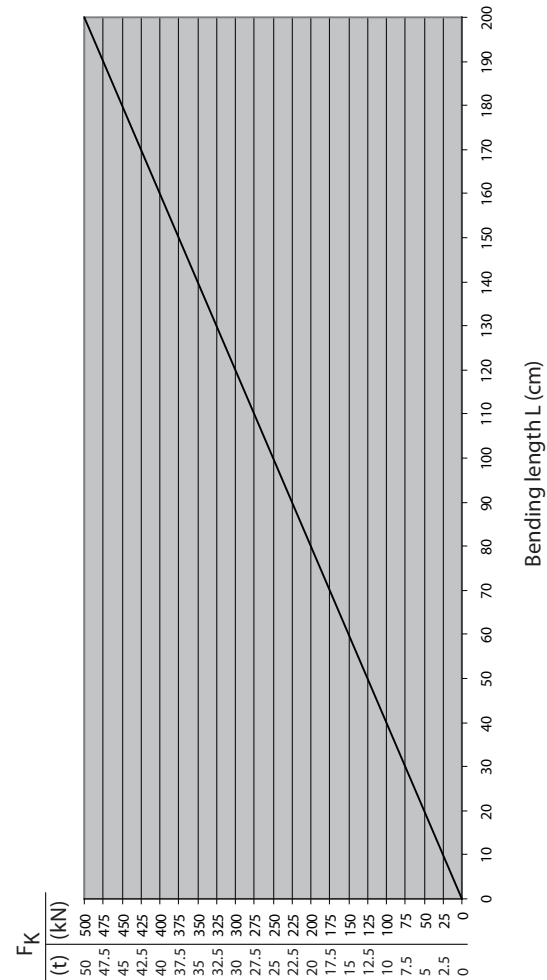

Maximum capacity of the hydrocushion 1000 kN/m (100 t/m)

## Calculation basics 3-point-bending

Working space on the Hämmerle 3-point-bending-machine

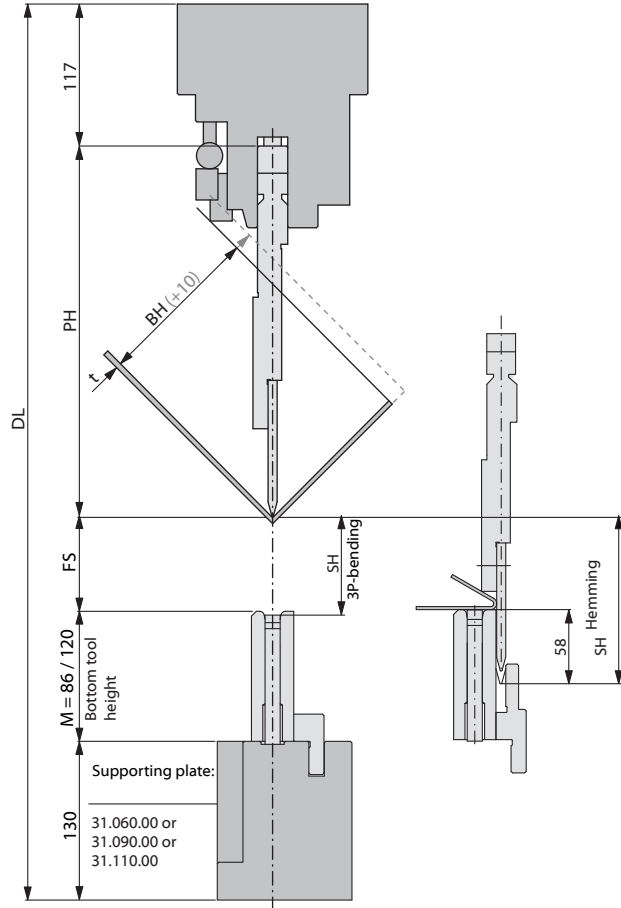

Maximum capacity of the hydrocushion 1000 kN/m (100 t/m)

## Calculation basics 3-point-bending

Working space on the Hämmerle 3-point-bending-machine

SH	DL	Typ	Typ	PH	FS (M = 86)	BH	Operation
Stroke	Open height	Punch holder	Punch	Top tool height	Free space	max. box height	Hemming
265	780	21.002.00	11.001.00	245	204	110	ja
		21.004.00	11.003.00	245	204	110	nein
		21.004.00	22.006.00 11.010.00	367	82	196	nein
		21.005.00	11.007.00	320	129	163	nein
400	915	21.002.00	11.001.00	245	339	110	ja
		21.002.00	11.003.00	295	289	145	nein
		21.003.00	22.006.00 11.010.01	330	254	170	nein
		21.004.00	11.003.00	245	339	110	nein
		21.004.00	12.015.00	245	339	110	nein
		21.004.00	22.006.00 11.010.01	367	217	196	nein
		21.005.00	11.001.00	350	234	184	ja
		21.005.00	11.003.00	400	184	219	nein
		21.005.00	11.007.00	320	264	163	nein
		21.005.00	12.015.00	400	184	219	nein
		21.010.00 *	11.001.00	400	184	219	ja
21.010.00 *	12.015.00	450	134	255	nein		

\* The top tool combinations are limited for sheet thickness up to max. of 3mm.

### Formula

For calculation of the max. boc height:  $BH (mm) = \frac{[PH (mm) - 90]}{\sqrt{2}}$





For calculation of the top tool height:  $PH (mm) = BH (mm) \times \sqrt{2} + 90$

## Description upper tools

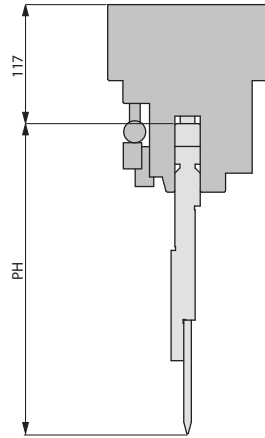
Hydraulic fast clamping system of the upper tools.

Hydraulic fast clamping system of the upper tools  
(Standard Hämmerle 3P)



-  1000 kN/m
-  vertical insertion
-  head supported
-  hydraulic
-  tools are reversible

Automatic centering of the tool during clamping ensures quick set up times. The segmented tool system offers total flexibility with regard to different bending lengths.

## Description upper tools

Upper tooling

1 set standard top tools

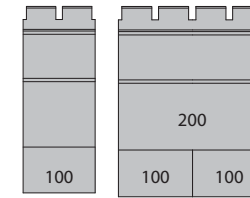

A top tool always consists of the punch and the punch holder. The punch holder is available in a length of L = 100mm or 200mm.

Upper tools - intermediate pieces - Intermediate pieces with horn

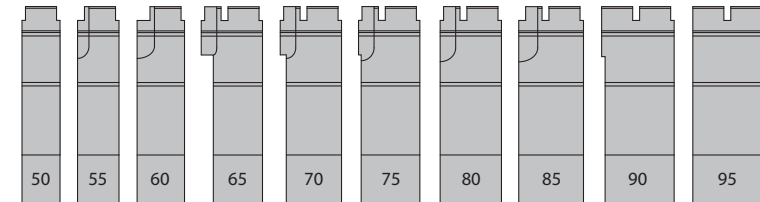

1 set of intermediate top tool sections without horn consists of 10 pieces.

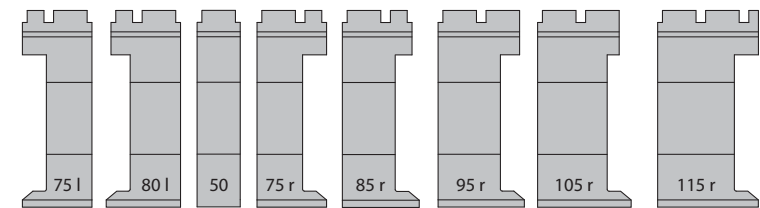

1 set of intermediate top tool sections with horn consists of 8 pieces.

## Description upper tools

## Standard holder and 3 point upper tool combination

punch holder	21.002.00	21.004.00	21.005.00
punch	11.001.00	12.015.00	11.001.00

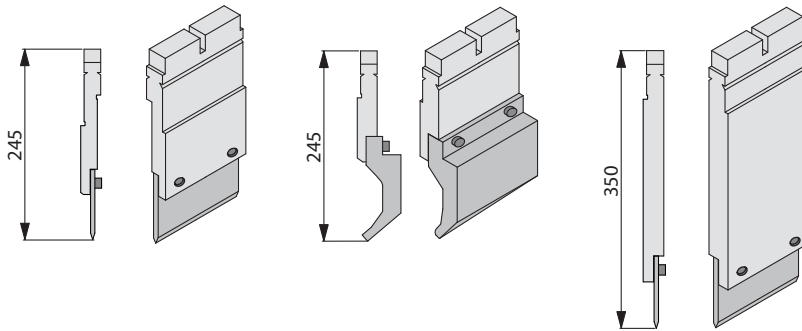

The max. permitted load of the tool combination is equal to the max. permitted load of the punch.

## Description upper tools

## Standard holder and 3 point upper tool combination

punch holder	21.005.00	21.010.00 *	21.010.00 *
punch	12.015.00	11.001.00	12.015.00

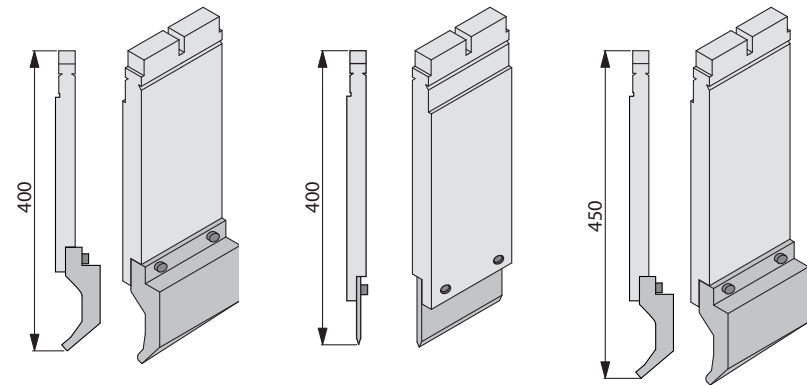

Top tool combinations with the punch holders 21.010.00 are limited for steel thickness up to max. 3mm.

## 11.001.00



	42 CrMo 4
	58 - 62 HRC
	F <sub>max</sub> = 1000 kN/m
	Operator side
	Head supported
	0.397 kg/100 mm
	Hämmerle 3P
	110.0 mm
	Ex stock / 24 h
	BH11001

[R] Radius (mm) 1

Nose angle 30°

[H] Height (mm) 90

[B] Width (mm) 6

Standard length	Part number
100 mm	B8-11.001.01.01
50 / 55 / 60 mm	B8-11.001.02.01 / 02 / 03
65 / 70 / 75 mm	B8-11.001.02.04 / 05 / 06
80 / 85 / 90 / 95 mm	B8-11.001.02.07 / 08 / 09 / 10
Horns 75 l / 80 l	B8-11.001.05.01 / 04.06
75 r / 85 r / 95 r / 105 r / 115 r	B8-11.001.04.01 / 02 / 03 / 04 / 05

## 11.001.00 + 21.002.00

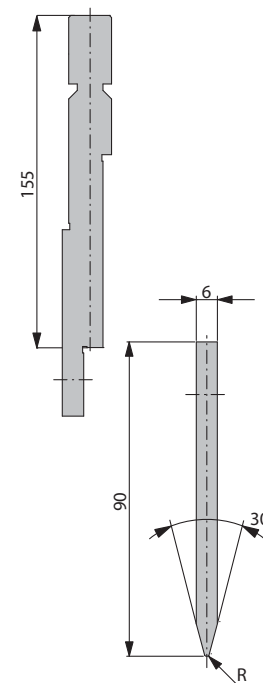

F = 1000 kN/m  
R = 1 mm  
H = 90 mm

Standard length	Part number
100 mm	B8-10.0001
200 mm	B8-10.0002
segmented 50 - 95	B8-10.0003
Horn set 50 - 115	B8-10.0014

11.028.00



[R] Radius (mm)	1
Nose angle	28°
[H] Height (mm)	90
[B] Width (mm)	6

	42 CrMo 4
	58 - 62 HRC
	F <sub>max</sub> = 1000 kN/m
	Operator side
	Head supported
	0.397 kg/100 mm
	Hämmerle 3P
	110.0 mm
	Ex stock / 24 h
	BH11028

Standard length	Part number
100 mm	B8-11.028.01.01
50 / 55 / 60 mm	B8-11.028.02.01 / 02 / 03
65 / 70 / 75 mm	B8-11.028.02.04 / 05 / 06
80 / 85 / 90 / 95 mm	B8-11.028.02.07 / 08 / 09 / 10
Horns 75 l / 80 l	B8-11.028.05.01 / 04.06
75 r / 85 r / 95 r / 105 r / 115 r	B8-11.028.04.01 / 02 / 03 / 04 / 05

11.028.00 + 21.002.00

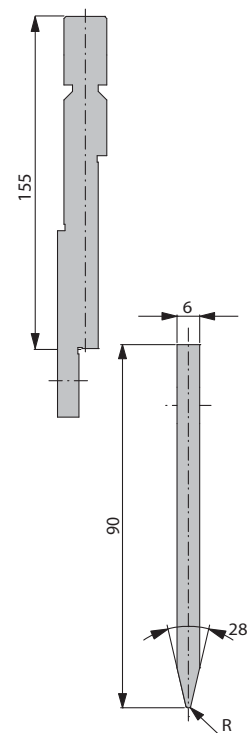

F = 1000 kN/m  
R = 1 mm  
H = 90 mm

Standard length	Part number
100 mm	B8-10.0001.1
200 mm	B8-10.0002.1
segmented 50 - 95	B8-10.0003.1
Horn set 50 - 115	B8-10.0014.1



## 11.003.00



[R] Radius (mm) 1

Nose angle 30

[H] Height (mm) 140

[B] Width (mm) 6

42 CrMo 4

58 - 62 HRC

Fmax = 1000 kN/m

Operator side

Head supported

0.627 kg/100 mm

Hämmerle 3P

110.0 mm

Ex stock / 24 h

BH11003

Standard length	Part number
100 mm	B8-11.003.01.01
50 / 55 / 60 mm	B8-11.003.02.01 / 02 / 03
65 / 70 / 75 mm	B8-11.003.02.04 / 05 / 06
80 / 85 / 90 / 95 mm	B8-11.003.02.07 / 08 / 09 / 10
Horns 75 l / 80 l	B8-11.003.05.01 / 04.06
75 r / 85 r / 95 r / 105 r / 115 r	B8-11.003.04.01 / 02 / 03 / 04 / 05

## 11.003.00 + 21.002.00

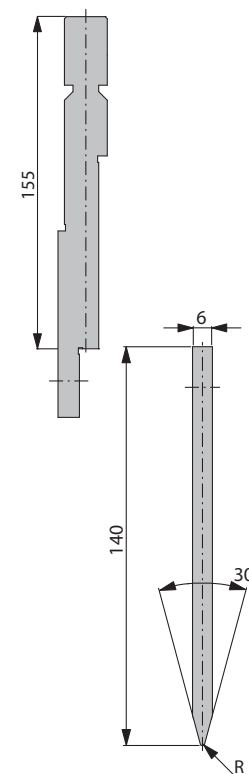

F = 1000 kN/m  
R = 1 mm  
H = 140 mm

Standard length	Part number
100 mm	B8-10.1717
200 mm	B8-10.1721
segmented 50 - 95	B8-10.1347
Horn set 50 - 115	B8-10.1348

11.006.00



[R] Radius (mm) 2

Nose angle 30

[H] Height (mm) 90

[B] Width (mm) 8

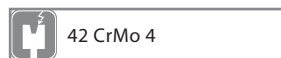

42 CrMo 4

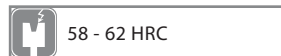

58 - 62 HRC

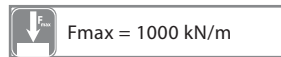

Fmax = 1000 kN/m

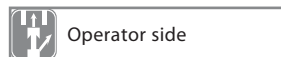

Operator side



Head supported

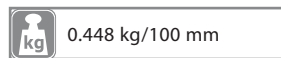

0.448 kg/100 mm



Hämmerle 3P

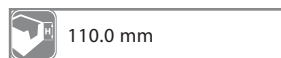

110.0 mm



Ex stock / 24 h



BH11006

Standard length	Part number
100 mm	B8-11.006.01.01
50 / 55 / 60 mm	B8-11.006.02.01 / 02 / 03
65 / 70 / 75 mm	B8-11.006.02.04 / 05 / 06
80 / 85 / 90 / 95 mm	B8-11.006.02.07 / 08 / 09 / 10
Horns 75 l / 80 l	B8-11.006.05.01 / 04.06
75 r / 85 r / 95 r / 105 r / 115 r	B8-11.006.04.01 / 02 / 03 / 04 / 05

11.006.00 + 21.002.00

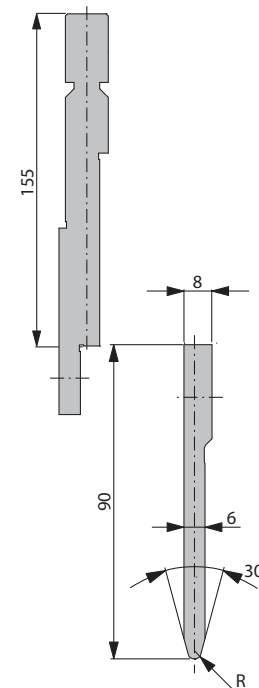

F = 1000 kN/m  
R = 2 mm  
H = 90 mm

Standard length	Part number
100 mm	B8-10.0098
200 mm	B8-10.0099
segmented 50 - 95	B8-10.0100
Horn set 50 - 115	B8-10.0111

## 11.008.00



	42 CrMo 4
	58 - 62 HRC
	F <sub>max</sub> = 1000 kN/m
	Operator side
	Head supported
	0.438 kg/100 mm
	Hämmerle 3P
	110.0 mm
	Ex stocki / 24 h
	BH11008

[R] Radius (mm) 1

Nose angle 30

[H] Height (mm) 90

[B] Width (mm) 8

Standard length	Part number
100 mm	B8-11.008.01.01
50 / 55 / 60 mm	B8-11.008.02.01 / 02 / 03
65 / 70 / 75 mm	B8-11.008.02.04 / 05 / 06
80 / 85 / 90 / 95 mm	B8-11.008.02.07 / 08 / 09 / 10
Horns 75 l / 80 l	B8-11.008.05.01 / 04.06
75 r / 85 r / 95 r / 105 r / 115 r	B8-11.008.04.01 / 02 / 03 / 04 / 05

## 11.008.00 + 21.002.00

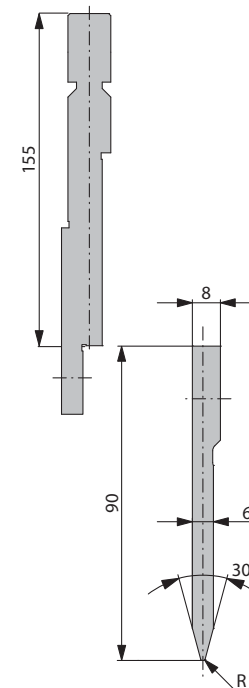











F = 1000 kN/m  
R = 1 mm  
H = 90 mm

Standard length	Part number
100 mm	B8-10.0160
200 mm	B8-10.0161
segmented 50 - 95	B8-10.0162
Horn set 50 - 115	B8-10.0173

11.010.00



-  42 CrMo4
-  58 - 62 HRC
-  Fmax = 600 kN/m
-  Operator side
-  Head supported
-  0.165 kg/100 mm
-  Hämmerle 3P
-  195.0 mm
-  Ex stock / 24 h
-  BH11010

[R] Radius (mm) 1

Nose angle 30

[H] Height (mm) 40

[B] Width (mm) 6

Standard length	Part number
100 mm	B8-11.010.01.01
50 / 55 / 60 mm	B8-11.010.02.01 / 02 / 03
65 / 70 / 75 mm	B8-11.010.02.04 / 05 / 06
80 / 85 / 90 / 95 mm	B8-11.010.02.07 / 08 / 09 / 10
Horns 75 l / 80 l	B8-11.010.05.01 / 04.06
75 r / 85 r / 95 r / 105 r / 115 r	B8-11.010.04.01 / 02 / 03 / 04 / 05

11.010.00 + 22.006.00 + 21.004.00

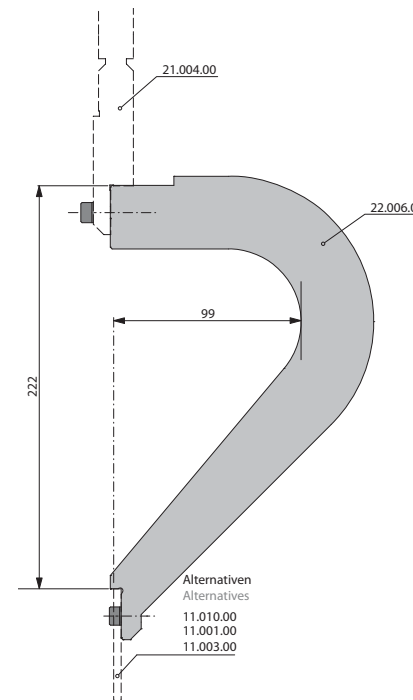

F = 600 kN/m  
R = 1 mm  
H = 40 mm

Standard length	Part number
100 mm	B8-10.1162
segmented 50 - 95	B8-10.1301

## 11.033.10



[R] Radius (mm) 3

Nose angle -

[H] Height (mm) 90

[B] Width (mm) 8

42 CrMo 4

58 - 62 HRC

Fmax = 1000 kN/m

Operator side

Head supported

0.451 kg/100 mm

Hämmerle 3P

110.0 mm

Ex stock / 24 h

BH11033

Standard length	Part number
100 mm	B8-11.033.11.01
50 / 55 / 60 mm	B8-11.033.12.01 / 02 / 03
65 / 70 / 75 mm	B8-11.033.12.04 / 05 / 06
80 / 85 / 90 / 95 mm	B8-11.033.12.07 / 08 / 09 / 10
Horns 75 l / 80 l	B8-11.033.15.01 / 14.06
75 r / 85 r / 95 r / 105 r / 115 r	B8-11.033.14.01 / 02 / 03 / 04 / 05

## 11.033.10 + 21.002.00

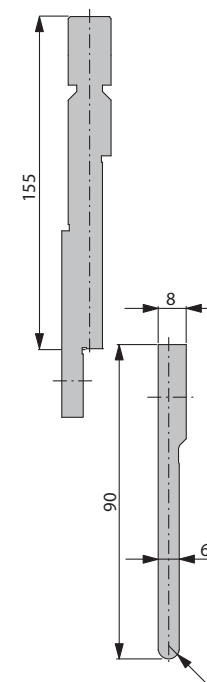

F = 1000 kN/m  
R = 3 mm  
H = 90 mm

Standard length	Part number
100 mm	B8-10.0424
200 mm	B8-10.0425
segmented 50 - 95	B8-10.0426
Horn set 50 - 115	B8-10.0437

## 11.034.00



 42 CrMo 4

 58 - 62 HRC

  $F_{max} = 1000 \text{ kN/m}$

 Operator side

 Head supported

 0.620 kg/100 mm

 Hämmerle 3P

 110.0 mm

 Ex stock / 24 h

 BOS No. BH11034

[R] Radius (mm) 4

Nose angle 30

[H] Height (mm) 90

[B] Width (mm) 8

Standard length	Part number
100 mm	B8-11.034.01.01
50 / 55 / 60 mm	B8-11.034.02.01 / 02 / 03
65 / 70 / 75 mm	B8-11.034.02.04 / 05 / 06
80 / 85 / 90 / 95 mm	B8-11.034.02.07 / 08 / 09 / 10
Horns 75 l / 80 l	B8-11.034.05.01 / 04.06
75 r / 85 r / 95 r / 105 r / 115 r	B8-11.034.04.01 / 02 / 03 / 04 / 05

## 11.034.00 + 21.002.00

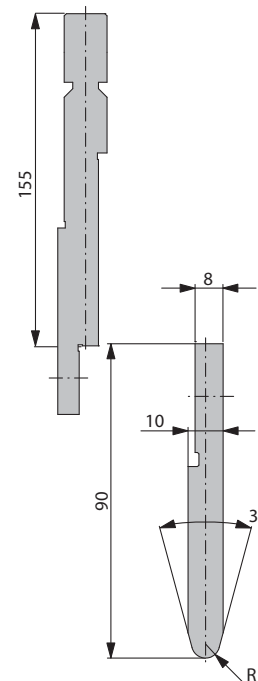

$F = 1000 \text{ kN/m}$   
 $R = 4 \text{ mm}$   
 $H = 90 \text{ mm}$

Standard length	Part number
100 mm	B8-10.0445
200 mm	B8-10.0446
segmented 50 - 95	B8-10.0447
Horn set 50 - 115	B8-10.1926

11.035.00

11.035.00 + 21.002.00



[R] Radius (mm) 5

Nose angle -

[H] Height (mm) 90

[B] Width (mm) 8

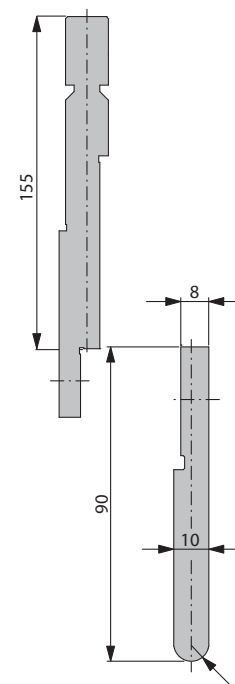
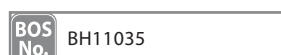
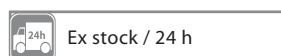
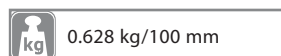
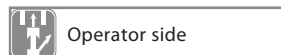
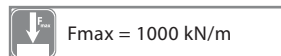
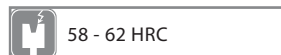

$F = 1000 \text{ kN/m}$   
 $R = 5 \text{ mm}$   
 $H = 90 \text{ mm}$

Standard length	Part number
100 mm	B8-11.035.01.01
50 / 55 / 60 mm	B8-11.035.02.01 / 02 / 03
65 / 70 / 75 mm	B8-11.035.02.04 / 05 / 06
80 / 85 / 90 / 95 mm	B8-11.035.02.07 / 08 / 09 / 10
Horns 75 l / 80 l	B8-11.035.05.01 / 04.06
75 r / 85 r / 95 r / 105 r / 115 r	B8-11.035.04.01 / 02 / 03 / 04 / 05

Standard length	Part number
100 mm	B8-10.0458
200 mm	B8-10.0459
segmented 50 - 95	B8-10.0460
Horn set 50 - 115	B8-10.0471

11.036.00



[R] Radius (mm) 6

Nose angle -

[H] Height (mm) 90

[B] Width (mm) 9

42 CrMo 4

58 - 62 HRC

Fmax = 1000 kN/m

Operator side

Head supported

0.733 kg/100 mm

Hämmerle 3P

110.0 mm

Ex stock / 24 h

BH11036

Standard length	Part number
100 mm	B8-11.036.01.01
50 / 55 / 60 mm	B8-11.036.02.01 / 02 / 03
65 / 70 / 75 mm	B8-11.036.02.04 / 05 / 06
80 / 85 / 90 / 95 mm	B8-11.036.02.07 / 08 / 09 / 10
Horns 75 l / 80 l	B8-11.036.05.01 / 04.06
75 r / 85 r / 95 r / 105 r / 115 r	B8-11.036.04.01 / 02 / 03 / 04 / 05

11.036.00 + 21.002.00

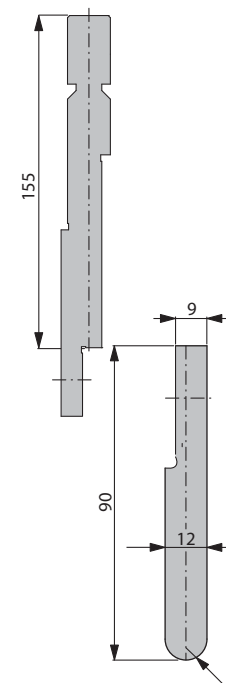

F = 1000 kN/m  
R = 6 mm  
H = 90 mm

Standard length	Part number
100 mm	B8-10.1240
200 mm	B8-10.1335
segmented 50 - 95	B8-10.1912
Horn set 50 - 115	B8-10.1927



## 12.014.00



[R] Radius (mm) 1

Nose angle 85

[H] Height (mm) 140

[B] Width (mm) 59

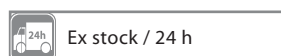
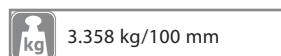
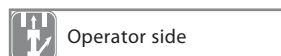
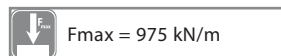
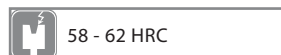

Standard length	Part number
100 mm	B8-12.014.01.01
50 / 55 / 60 mm	B8-12.014.02.01 / 02 / 03
65 / 70 / 75 mm	B8-12.014.02.04 / 05 / 06
80 / 85 / 90 / 95 mm	B8-12.014.02.07 / 08 / 09 / 10
Horns 75 l / 80 l	B8-12.014.05.01 / 04.06
75 r / 85 r / 95 r / 105 r / 115 r	B8-12.014.04.01 / 02 / 03 / 04 / 05

## 12.014.00 + 21.004.00

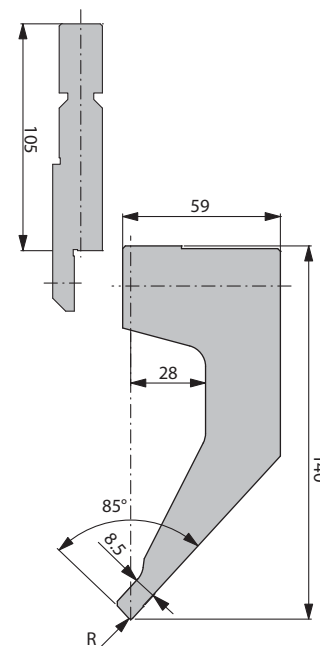

F = 975 kN/m  
R = 1 mm  
H = 140 mm

Standard length	Part number
100 mm	B8-10.0243
200 mm	B8-10.0244
segmented 50 - 95	B8-10.0245
Horn set 50 - 115	B8-10.0256

## 12.015.00



[R] Radius (mm) 1

Nose angle 85

[H] Height (mm) 140

[B] Width (mm) 45

	42 CrMo 4
	58 - 62 HRC
	Fmax = 975 kN/m
	Operator side
	Head supported
	2.620 kg/100 mm
	Hämmerle 3P
	110.0 mm
	Ex stock / 24 h
	BH12015

Standard length	Part number
100 mm	B8-12.015.01.01
50 / 55 / 60 mm	B8-12.015.02.01 / 02 / 03
65 / 70 / 75 mm	B8-12.015.02.04 / 05 / 06
80 / 85 / 90 / 95 mm	B8-12.015.02.07 / 08 / 09 / 10
Horns 75 l / 80 l	B8-12.015.05.01 / 04.06
75 r / 85 r / 95 r / 105 r / 115 r	B8-12.015.04.01 / 02 / 03 / 04 / 05

## 12.015.00 + 21.004.00

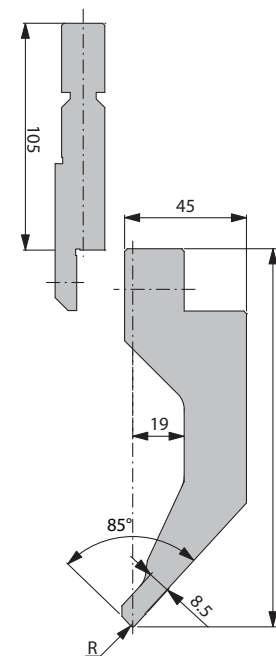

F = 975 kN/m  
R = 1 mm  
H = 140 mm

Standard length	Part number
100 mm	B8-10.0285
200 mm	B8-10.0286
segmented 50 - 95	B8-10.0287
Horn set 50 - 115	B8-10.0298

## 12.017.00



	42 CrMo 4
	58 - 62 HRC
	F <sub>max</sub> = 750 kN/m
	Operator side
	Head supported
	2.755 kg/100 mm
	Hämmerle 3P
	145.0 mm
	Ex stock / 24 h
	BH12017

[R] Radius (mm) 1

Nose angle 55

[H] Height (mm) 190

[B] Width (mm) 34

Standard length	Part number
100 mm	B8-12.017.01.01
50 / 55 / 60 mm	B8-12.017.02.01 / 02 / 03
65 / 70 / 75 mm	B8-12.017.02.04 / 05 / 06
80 / 85 / 90 / 95 mm	B8-12.017.02.07 / 08 / 09 / 10
Horns 75 l / 80 l	B8-12.017.05.01 / 04.06
75 r / 85 r / 95 r / 105 r / 115 r	B8-12.017.04.01 / 02 / 03 / 04 / 05

## 12.017.00 + 21.004.00

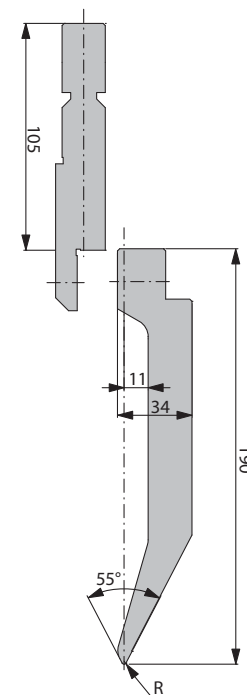

F = 750 kN/m  
R = 1 mm  
H = 190 mm

Standard length	Part number
100 mm	B8-10.1400
200 mm	B8-10.1401
segmented 50 - 95	B8-10.1402
Horn set 50 - 115	B8-10.1928

## 12.025.00



	42 CrMo 4
	58 - 62 HRC
	Fmax = 250 kN/m
	Operator side
	Head supported
	1.354 kg/100 mm
	Hämmerle 3P
	110.0 mm
	Ex stock / 24 h
	BH12025

[R] Radius (mm) 1

Nose angle 85

[H] Height (mm) 140

[B] Width (mm) 22

Standard length	Part number
100 mm	B8-12.025.01.01
50 / 55 / 60 mm	B8-12.025.02.01 / 02 / 03
65 / 70 / 75 mm	B8-12.025.02.04 / 05 / 06
80 / 85 / 90 / 95 mm	B8-12.025.02.07 / 08 / 09 / 10
Horns 75 l / 80 l	B8-12.025.05.01 / 04.06
75 r / 85 r / 95 r / 105 r / 115 r	B8-12.025.04.01 / 02 / 03 / 04 / 05

## 12.025.00 + 21.004.00

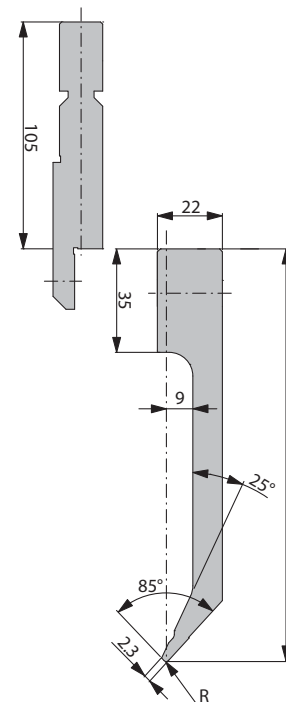

F = 250 kN/m  
R = 1 mm  
H = 140 mm

Standard length	Part number
100 mm	B8-10.1506
200 mm	B8-10.1507
segmented 50 - 95	B8-10.1929
Horn set 50 - 115	B8-10.1930

12.052.00



[R] Radius (mm) 2

Nose angle 85

[H] Height (mm) 140

[B] Width (mm) 45



42 CrMo 4

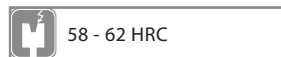

58 - 62 HRC

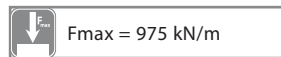

Fmax = 975 kN/m

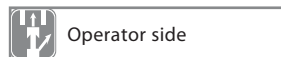

Operator side



Head supported

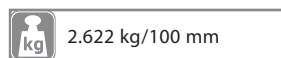

2.622 kg/100 mm



Hämmerle 3P

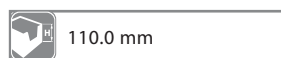

110.0 mm



Ex stock / 24 h

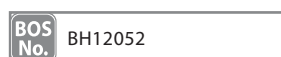

BH12052

Standard length	Part number
100 mm	B8-12.052.01.01
50 / 55 / 60 mm	B8-12.052.02.01 / 02 / 03
65 / 70 / 75 mm	B8-12.052.02.04 / 05 / 06
80 / 85 / 90 / 95 mm	B8-12.052.02.07 / 08 / 09 / 10
Horns 75 l / 80 l	B8-12.052.05.01 / 04.06
75 r / 85 r / 95 r / 105 r / 115 r	B8-12.052.04.01 / 02 / 03 / 04 / 05

12.052.00 + 21.004.00

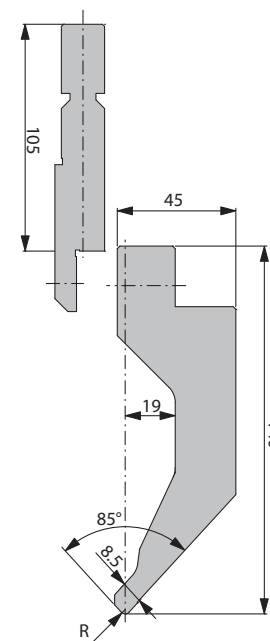

F = 975 kN/m

R = 2 mm

H = 140 mm

Standard length	Part number
100 mm	B8-10.0479
200 mm	B8-10.0480
segmented 50 - 95	B8-10.0481
Horn set 50 - 115	B8-10.0492

12.053.00



[R] Radius (mm) 3

Nose angle 85

[H] Height (mm) 140

[B] Width (mm) 45



42 CrMo 4

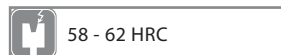

58 - 62 HRC

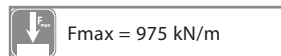

Fmax = 975 kN/m

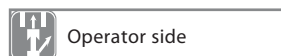

Operator side



Head supported

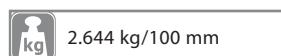

2.644 kg/100 mm



Hämmerle 3P



110.0 mm

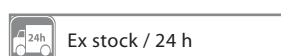

Ex stock / 24 h

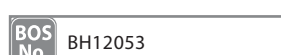

BH12053

Standard length	Part number
100 mm	B8-12.053.01.01
50 / 55 / 60 mm	B8-12.053.02.01 / 02 / 03
65 / 70 / 75 mm	B8-12.053.02.04 / 05 / 06
80 / 85 / 90 / 95 mm	B8-12.053.02.07 / 08 / 09 / 10
Horns 75 l / 80 l	B8-12.053.05.01 / 04.06
75 r / 85 r / 95 r / 105 r / 115 r	B8-12.053.04.01 / 02 / 03 / 04 / 05

12.053.00 + 21.004.00

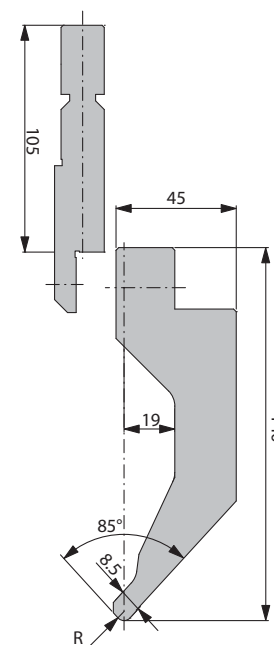

F = 975 kN/m  
R = 3 mm  
H = 140 mm

Standard length	Part number
100 mm	B8-10.0500
200 mm	B8-10.0501
segmented 50 - 95	B8-10.0502
Horn set 50 - 115	B8-10.0513

12.065.00



[R] Radius (mm) 1

Nose angle 50

[H] Height (mm) 140

[B] Width (mm) 16

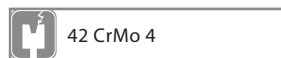

42 CrMo 4

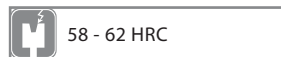

58 - 62 HRC

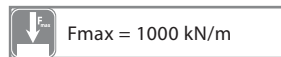

Fmax = 1000 kN/m

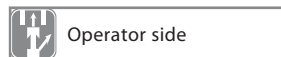

Operator side



Head supported

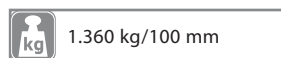

1.360 kg/100 mm



Hämmerle 3P



110.0 mm



Ex stock / 24 h



BH12065

12.065.00 + 21.004.00

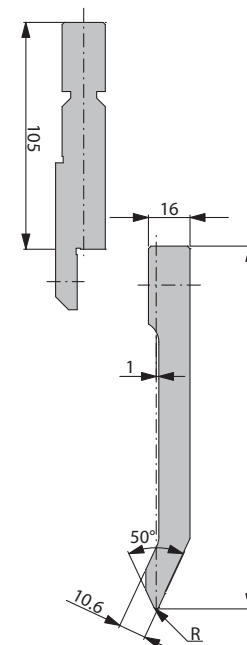

F = 1000 kN/m

R = 1 mm

H = 140 mm

**Standard length****Part number**

100 mm	B8-12.065.01.01
50 / 55 / 60 mm	B8-12.065.02.01 / 02 / 03
65 / 70 / 75 mm	B8-12.065.02.04 / 05 / 06
80 / 85 / 90 / 95 mm	B8-12.065.02.07 / 08 / 09 / 10
Horns 75 l / 80 l	B8-12.065.05.01 / 04.06
75 r / 85 r / 95 r / 105 r / 115 r	B8-12.065.04.01 / 02 / 03 / 04 / 05

**Standard length****Part number**

100 mm	B8-10.0521
200 mm	B8-10.0522
segmented 50 - 95	B8-10.0523
Horn set 50 - 115	B8-10.0534

14.021.00



[R] Radius (mm) -

Nose angle -

[H] Height (mm) 140

[B] Width (mm) 10

42 CrMo 4

58 - 62 HRC

Fmax = 1000 kN/m

Operator side

Head supported

1.085 kg/100 mm

Hämmerle 3P

---

Ex stock / 24 h

BH14021

Standard length	Part number
100 mm	B8-14.021.01.01
50 / 55 / 60 mm	B8-14.021.02.01 / 02 / 03
65 / 70 / 75 mm	B8-14.021.02.04 / 05 / 06
80 / 85 / 90 / 95 mm	B8-14.021.02.07 / 08 / 09 / 10

14.021.00 + 21.004.00

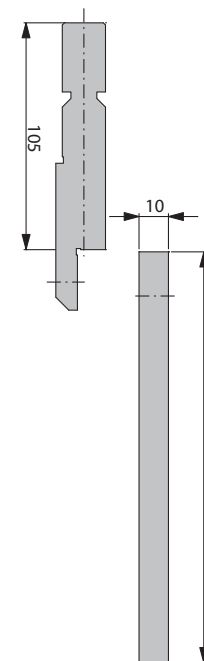

F = 1000 kN/m

R = ---

H = 140 mm

Standard length	Part number
100 mm	B8-10.0369
200 mm	B8-10.0370
segmented 50 - 95	B8-10.0371



22.006.00



[R] Radius (mm) -

Nose angle -

[H] Height (mm) 222

[B] Width (mm) 99

42 CrMo 4

---

 $F_{max} = 600 \text{ kN/m}$ 

Operator side

Head supported

10.300 kg/100 mm

Hämmerle 3P

variable

Ex stock / 24 h

BH22006

Standard length	Part number
100 mm	B8-22.006.01.01
50 / 55 / 60 mm	B8-22.006.02.01 / 02 / 03
65 / 70 / 75 mm	B8-22.006.02.04 / 05 / 06
80 / 85 / 90 / 95 mm	B8-22.006.02.07 / 08 / 09 / 10

22.006.00 + 21.004.00

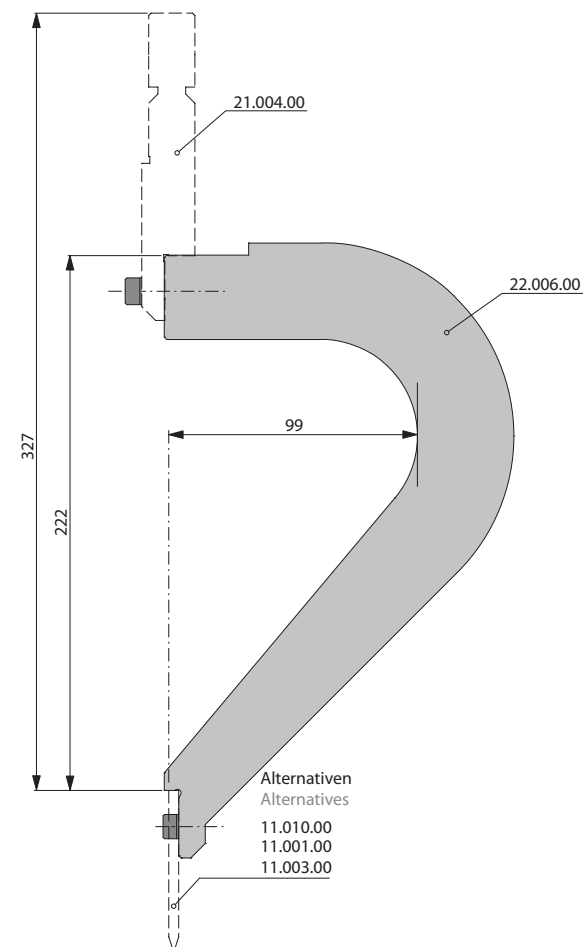

F = 600 kN/m

R = ---

H = 222

Alternativen

Alternatives

11.010.00

11.001.00

11.003.00

## Radius punch holder 22.013.00

22.013.00



[R] Radius (mm) 6-12.5

Nose angle -

[H] Height (mm) 120

[B] Width (mm) 37

	42 CrMo 4
	---
	F <sub>max</sub> = 1000 kN/m
	Operator side
	Head supported
	2.820 kg/100 mm
	Hämmerle 3P
	variable
	Ex stock / 24 h
	BH22013

F = 1000 kN/m  
R = ---  
H = 120

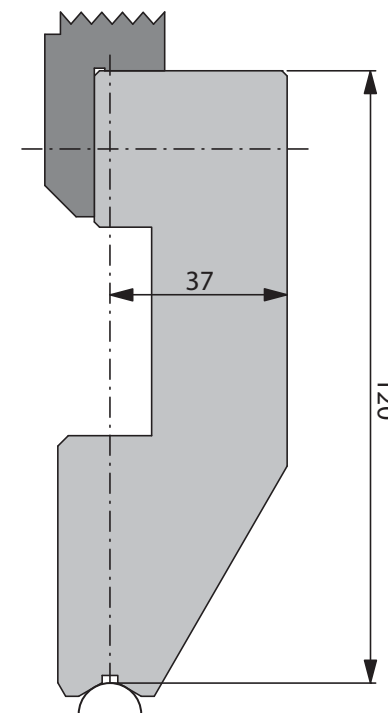

## Standard length

## Part number

100 mm	B8-22.013.01.01
50 / 55 / 60 mm	B8-22.013.02.01 / 02 / 03
65 / 70 / 75 mm	B8-22.013.02.04 / 05 / 06
80 / 85 / 90 / 95 mm	B8-22.013.02.07 / 08 / 09 / 10

## Radius punch holder 22.014.00

22.014.00



[R] Radius (mm) 8-20

Nose angle -

[H] Height (mm) 120

[B] Width (mm) 37

	42 CrMo 4
	---
	F <sub>max</sub> = 1000 kN/m
	Operator side
	Head supported
	3.050 kg/100 mm
	Hämmerle 3P
	variable
	Ex stock / 24 h
	BH22014

F = 1000 kN/m  
 R = ----  
 H = 120 mm

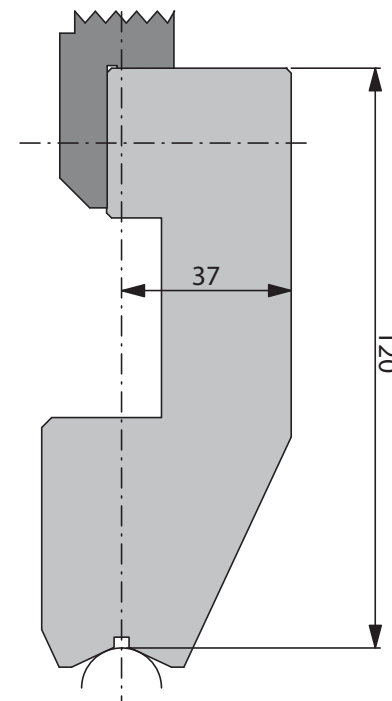

## Standard length

## Part number

100 mm	B8-22.014.01.01
50 / 55 / 60 mm	B8-22.014.02.01 / 02 / 03
65 / 70 / 75 mm	B8-22.014.02.04 / 05 / 06
80 / 85 / 90 / 95 mm	B8-22.014.02.07 / 08 / 09 / 10

## Radius punch holder 22.015.00

22.015.00



[R] Radius (mm) 18-45

Nose angle -

[H] Height (mm) 112

[B] Width (mm) 40.5

42 CrMo 4

---

 F<sub>max</sub> = 1000 kN/m

Operator side

Head supported

3.280 kg/100 mm

Hämmerle 3P

variable

Ex stock / 24 h

BH22015

Standard length	Part number
100 mm	B8-22.015.01.01
50 / 55 / 60 mm	B8-22.015.02.01 / 02 / 03
65 / 70 / 75 mm	B8-22.015.02.04 / 05 / 06
80 / 85 / 90 / 95 mm	B8-22.015.02.07 / 08 / 09 / 10

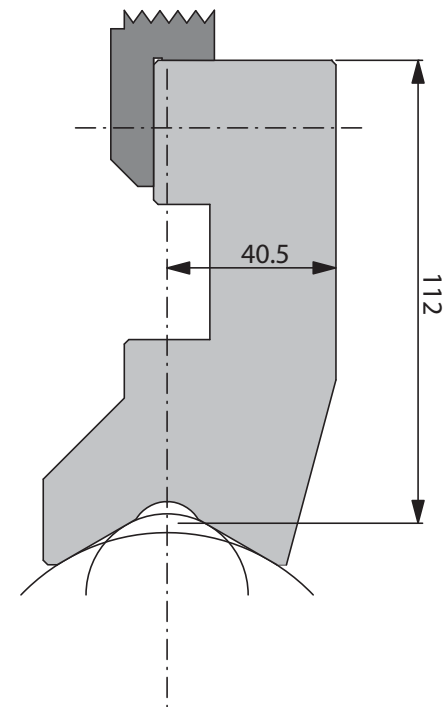

F = 1000 kN/m  
R = ---  
H = 112 mm

## Coining upper tool 11.005.00



[R] Radius (mm) -

Nose angle 90

[H] Height (mm) 90

[B] Width (mm) 6

Standard length	Part number
100 mm	B8-11.005.01.01
50 / 55 / 60 mm	B8-11.005.02.01 / 02 / 03
65 / 70 / 75 mm	B8-11.005.02.04 / 05 / 06
80 / 85 / 90 / 95 mm	B8-11.005.02.07 / 08 / 09 / 10

## 11.005.00 + 21.002.00

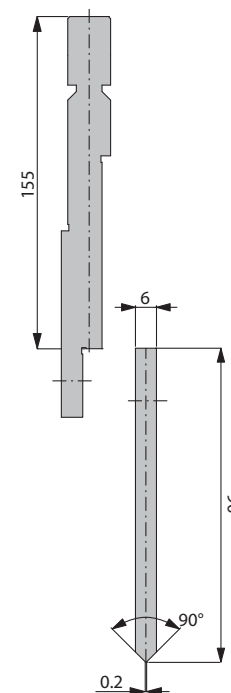

F = 1000 kN/m

R = ---

H = 90 mm

Standard length	Part number
100 mm	B8-10.0077
200 mm	B8-10.0078
segmented 50 - 95	B8-10.0079

## Coining upper tool 11.009.10



	42 CrMo 4
	58 - 62 HRC
	F <sub>max</sub> = 1000 kN/m
	Operator side
	Head supported
	1.20 kg/100 mm
	Hämmerle 3P
	150.0 mm
	Ex stock / 24 h
	BH11009

[R] Radius (mm) -

Nose angle 90

[H] Height (mm) 140

[B] Width (mm) 12

Standard length	Part number
100 mm	B8-11.009.11.01
50 / 55 / 60 mm	B8-11.009.12.01 / 02 / 03
65 / 70 / 75 mm	B8-11.009.12.04 / 05 / 06
80 / 85 / 90 / 95 mm	B8-11.009.12.07 / 08 / 09 / 10

## 11.009.10 + 21.002.00

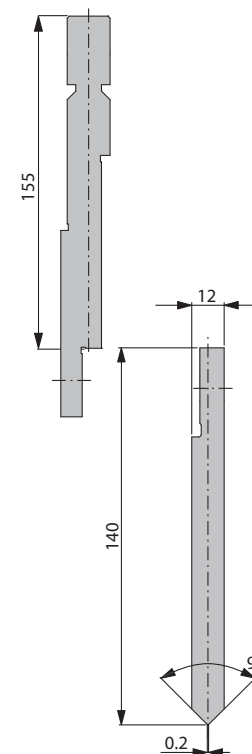

F = 1000 kN/m  
 R = ---  
 H = 140 mm

Standard length	Part number
100 mm	B8-10.1511
200 mm	B8-10.1931
segmented 50 - 95	B8-10.1512

## Coining upper tool 12.019.00



[R] Radius (mm) 1

Nose angle 90

[H] Height (mm) 140

[B] Width (mm) 45

42 CrMo 4

58 - 62 HRC

 $F_{max} = 975 \text{ kN/m}$ 

Operator side

Head supported

2.60 kg/100 mm

Hämmerle 3P

110.0 mm

Ex stock / 24 h

BOS No. BH12019

## Standard length

## Part number

100 mm	B8-12.019.01.01
50 / 55 / 60 mm	B8-12.019.02.01 / 02 / 03
65 / 70 / 75 mm	B8-12.019.02.04 / 05 / 06
80 / 85 / 90 / 95 mm	B8-12.019.02.07 / 08 / 09 / 10

## 12.019.00 + 21.004.00

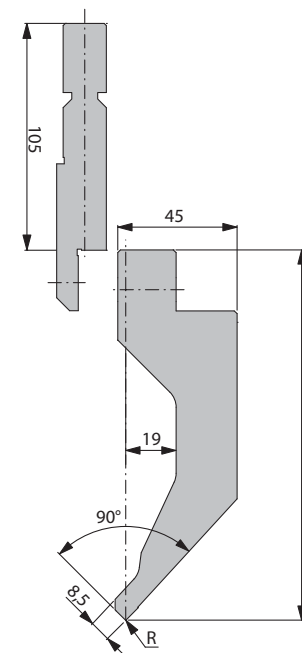

 $F = 975 \text{ kN/m}$   
 $R = 1 \text{ mm}$   
 $H = 140 \text{ mm}$ 

## Standard length

## Part number

100 mm	B8-10.0327
200 mm	B8-10.0328
segmented 50 - 95	B8-10.0329

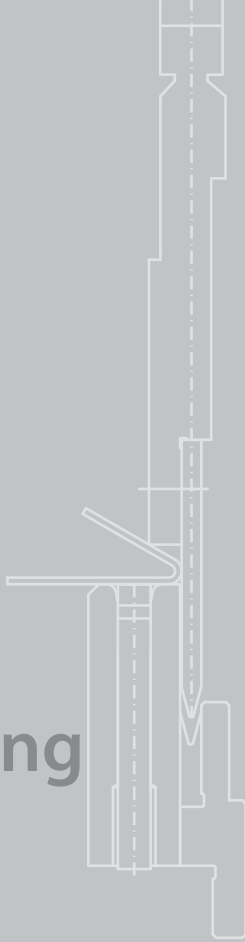
## Bottom tools 3 - point - bending



## Bottom tools 3-point-bending

### Recommendation starterkit Hämmerle 3P

Bend length	Part number	Description	Piece	Unit
2100 mm	B8-10.0001.1	Punch + holder 11.028.00/21.002.00/100	17	pieces
	B8-10.0002.1	Punch + holder 11.028.00/21.002.00/200	2	pieces
	B8-10.0646	Die kpl.GS/Fld. 31.012.00/WL100	6	pieces
	B8-10.0647	Die kpl.GS/Fld. 31.012.00/WL500	3	pieces
3100 mm	B8-10.0001.1	Punch + holder 11.028.00/21.002.00/100	27	pieces
	B8-10.0002.1	Punch + holder 11.028.00/21.002.00/200	2	pieces
	B8-10.0646	Die kpl.GS/Fld. 31.012.00/WL100	6	pieces
	B8-10.0647	Die kpl.GS/Fld. 31.012.00/WL500	5	pieces
4100 mm	B8-10.0001.1	Punch + holder 11.028.00/21.002.00/100	37	pieces
	B8-10.0002.1	Punch + holder 11.028.00/21.002.00/200	2	pieces
	B8-10.0646	Die kpl.GS/Fld. 31.012.00/WL100	6	pieces
	B8-10.0647	Die kpl.GS/Fld. 31.012.00/WL500	7	pieces



## Description bottom tools

### Hydraulic fast clamping system of the bottom tools

Hydraulic fast clamping system of the bottom tools  
(Standard Hämmerle 3P)

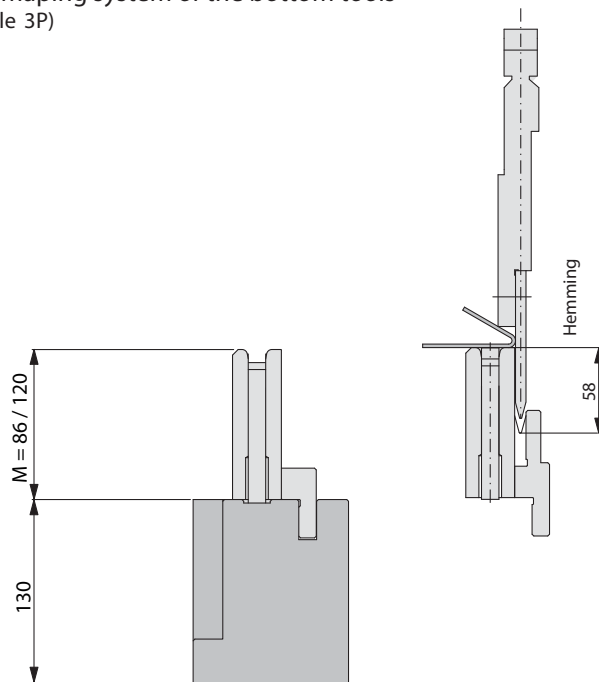

60-62 HRC



1000 kN/m



hydraulic

Shortest setup times  
are guaranteed by  
the hydraulic quick  
clamping system of  
the lower tools.

## Description bottom tools

### Bottom tools segmentation

Bottom tool intermediate pieces

For bottom tools up to 60mm V-opening intermediate pieces are also available.  
1 set consists of 10 intermediate pieces.

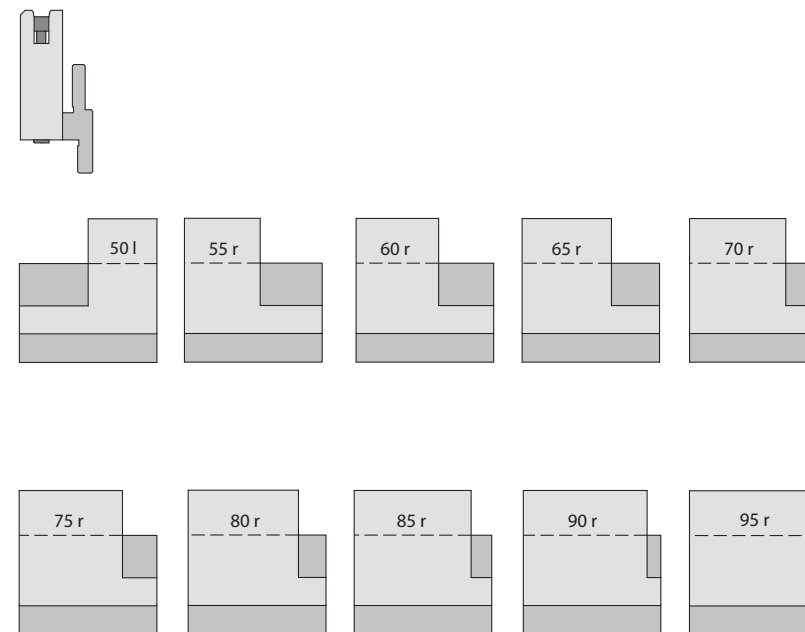

## Description bottom tools

### Standard pieces

#### Bottom tools

Indications with regards to material thickness and angle range refer to mild steel plates with a tensile strength of  $R_m = 450 \text{ N/mm}^2$ .

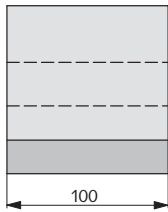
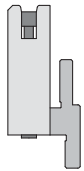

Standard bottom tool piece  $L = 100 \text{ mm}$  with holding rail  $L = 100 \text{ mm}$ .

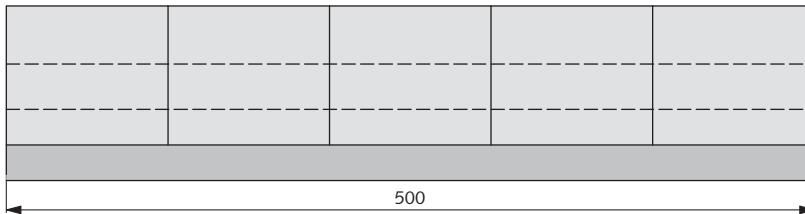

5 standard bottom tools with holding rail  $L = 500 \text{ mm}$ .

A bottom tool always consists of the basic bottom tool body, a holding rail and the bottom tool pins.

## Notes



### 31.005.00 H-S

### 31.005.00 H-FLD

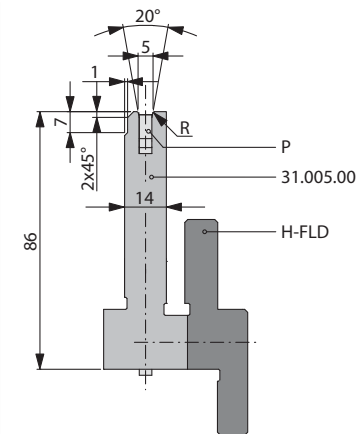
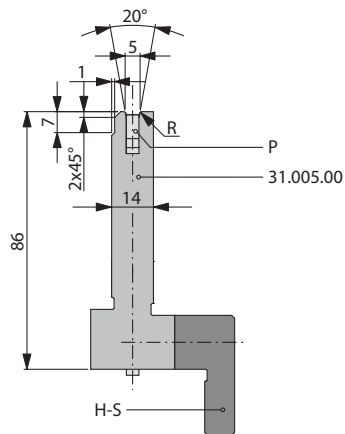



[R] Radius (mm)	0.6
V - Angle	30-180
[H] Height (mm)	86
[B] Width (mm)	14
Material thickness (mm)	0.5 - 1

[R] Radius (mm)	0.6
V - Angle	30-180
[H] Height (mm)	86
[B] Width (mm)	14
Material thickness (mm)	0.5 - 1

 42 CrMo 4

 58 - 62 HRC

 F<sub>max</sub> = 250 kN/m

 1.70 Kg/100 mm

 Hämmerle 3P

 Ex stock / 24 h

 005.00-01

 42 CrMo 4

 58 - 62 HRC

 F<sub>max</sub> = 250 kN/m

 1.70 kg/100 mm

 Hämmerle 3P

 Ex stock / 24 h

 005.00-08

Standard length	Part number
100 mm	B8-10.1250
500 mm	B8-10.1255
segmented 50 - 95	B8-10.1256

Standard length	Part number
100 mm	B8-10.0946
500 mm	B8-10.0947
segmented 50 - 95	B8-10.0948

### 31.006.00 H-S

### 31.006.00 H-FLD

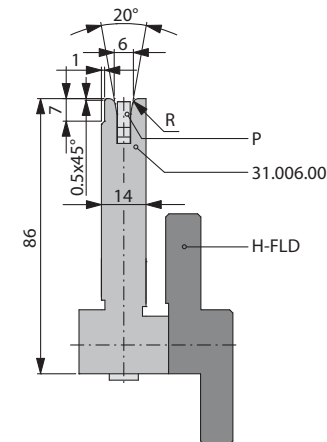
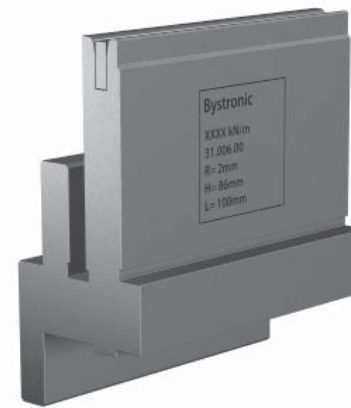
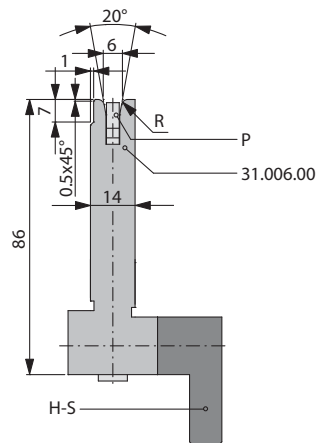

[R] Radius (mm)	2
V - Angle	30-180
[H] Height (mm)	86
[B] Width (mm)	14
Material thickness (mm)	0.5 - 1.25

[R] Radius (mm)	2
V - Angle	30-180
[H] Height (mm)	86
[B] Width (mm)	14
Material thickness (mm)	0.5 - 1.25

42 CrMo 4

58 - 62 HRC

F<sub>max</sub> = 350 kN/m

1.71 Kg/100 mm

Hämmerle 3P

Ex stock / 24 h

006.00-01

42 CrMo 4

56 - 62 HRC

F<sub>max</sub> = 350 kN/m

1.71 kg/100 mm

Hämmerle 3P

Ex stock / 24 h

006.00-08

Standard length	Part number
100 mm	B8-10.1535
500 mm	B8-10.1536
segmented 50 - 95	B8-10.1537

Standard length	Part number
100 mm	B8-10.1420
500 mm	B8-10.1421
segmented 50 - 95	B8-10.1422

### 31.007.00 H-S

### 31.007.00 H-FLD

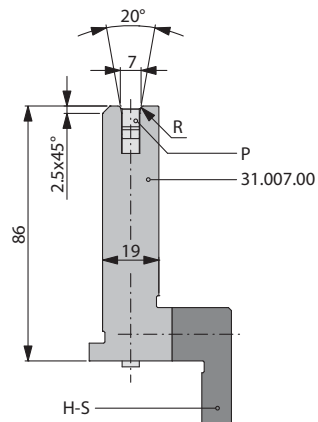

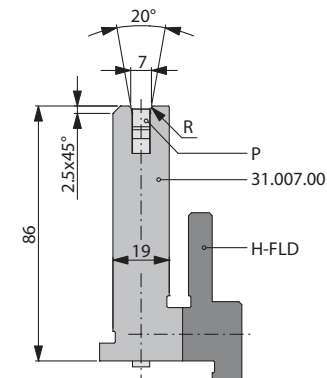

[R] Radius (mm)	1
V - Angle	30-180
[H] Height (mm)	86
[B] Width (mm)	19
Material thickness (mm)	0.5 - 1.5



[R] Radius (mm)	1
V - Angle	30-180
[H] Height (mm)	86
[B] Width (mm)	19
Material thickness (mm)	0.5 - 1.5

 42 CrMo 4

 58 - 62 HRC

 F<sub>max</sub> = 500 kN/m

 1.87 Kg/100 mm

 Hämmerle 3P

 Ex stock / 24 h

 007.00-01

 42 CrMo 4

 58 - 62 HRC

 F<sub>max</sub> = 500 kN/m

 1.87 kg/100 mm

 Hämmerle 3P

 Ex stock / 24 h

 007.00-02

Standard length	Part number
100 mm	B8-10.0542
500 mm	B8-10.0543
segmented 50 - 95	B8-10.0544

Standard length	Part number
100 mm	B8-10.0555
500 mm	B8-10.0556
segmented 50 - 95	B8-10.0557

### 31.007.20 H-S

### 31.007.20 H-FLD

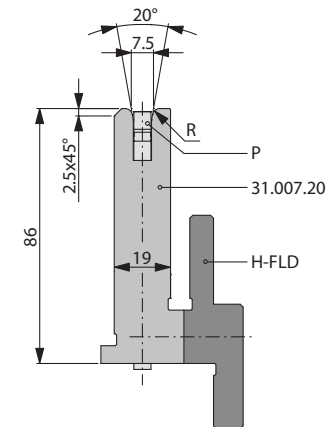
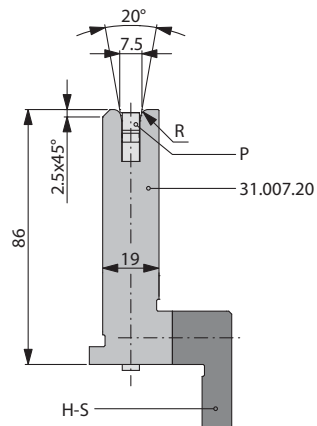

[R] Radius (mm)	2.5
V - Angle	30-180
[H] Height (mm)	86
[B] Width (mm)	19
Material thickness (mm)	0.5 - 1.5

[R] Radius (mm)	2.5
V - Angle	30-180
[H] Height (mm)	86
[B] Width (mm)	19
Material thickness (mm)	0.5 - 1.5

42 CrMo 4

58 - 62 HRC

F<sub>max</sub> = 500 kN/m

1.86 Kg/100 mm

Hämmerle 3P

Ex stock / 24 h

007.20-01

42 CrMo4

58 - 62 HRC

F<sub>max</sub> = 500 kN/m

1.86 kg/100 mm

Hämmerle 3P

Ex Stock / 24 h

007.20-02

Standard length	Part number
100 mm	B8-10.0568
500 mm	B8-10.0569
segmented 50 - 95	B8-10.0570

Standard length	Part number
100 mm	B8-10.0581
500 mm	B8-10.0582
segmented 50 - 95	B8-10.0583

### 31.010.20 H-S

### 31.012.00 H-S

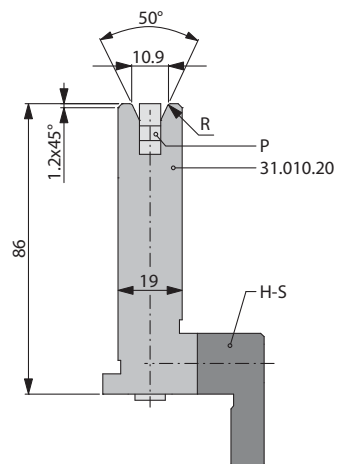

[R] Radius (mm)	1
V - Angle	85-180
[H] Height (mm)	86
[B] Width (mm)	19
Material thickness (mm)	0.7 - 2.5

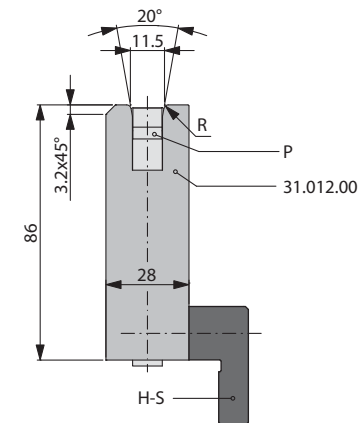

[R] Radius (mm)	1.5
V - Angle	30-180
[H] Height (mm)	86
[B] Width (mm)	28
Material thickness (mm)	0.7 - 3.0

Standard length	Part number
100 mm	B8-10.0620
500 mm	B8-10.0621
segmented 50 - 95	B8-10.0622

Standard length	Part number
100 mm	B8-10.0633
500 mm	B8-10.0634
segmented 50 - 95	B8-10.0635

42 CrMo 4

58 - 62 HRC

F<sub>max</sub> = 550 kN/m

1.70 Kg/100 mm

Hämmerle 3P

Ex stock / 24 h

010.20-01

42 CrMo 4

58 - 62 HRC

F<sub>max</sub> = 500 kN/m

2.39 kg/100 mm

Hämmerle 3P

Ex stock / 24 h

012.00-01

### 31.012.00 H-FLD

### 31.013.00 H-S

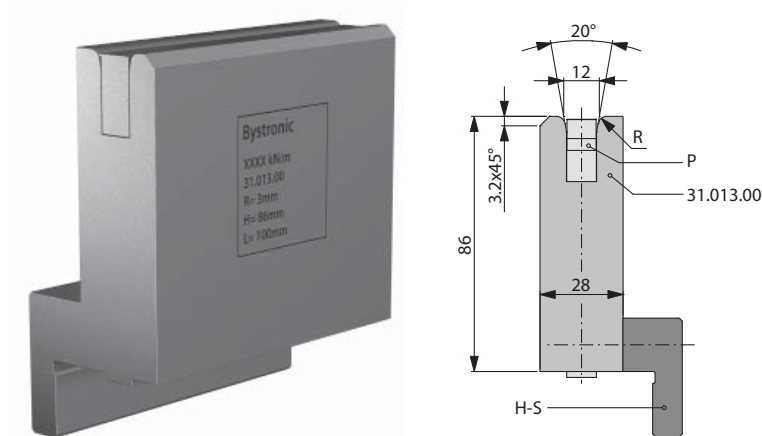
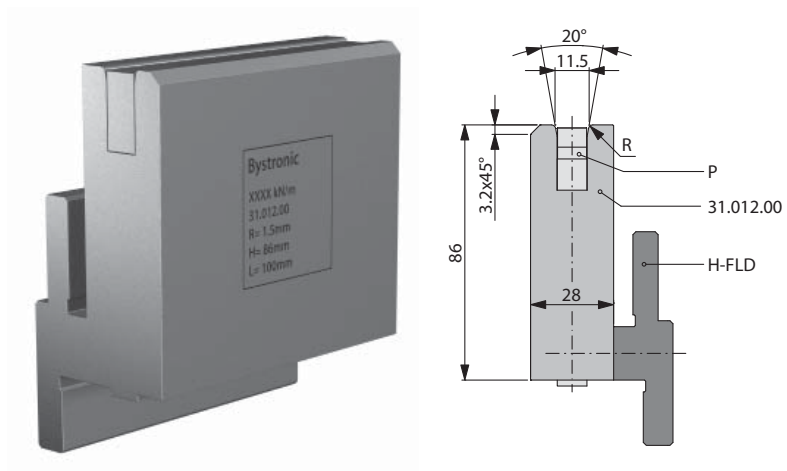

[R] Radius (mm)	1.5
V - Angle	30-180
[H] Height (mm)	86
[B] Width (mm)	28
Material thickness (mm)	0.7 - 3.0

[R] Radius (mm)	3
V - Angle	30-180
[H] Height (mm)	86
[B] Width (mm)	28
Material thickness (mm)	0.7 - 3.0

42 CrMo 4

42 CrMo 4

58 - 62 HRC

58 - 62 HRC

F<sub>max</sub> = 500 kN/m

F<sub>max</sub> = 500 kN/m

2.39 Kg/100 mm

2.40 kg/100 mm

Hämmerle 3P

Hämmerle 3P

Ex Stock / 24 h

Ex stock / 24 h

012.00-03

013.00-01

Standard length	Part number
100 mm	B8-10.0646
500 mm	B8-10.0647
segmented 50 - 95	B8-10.0648

Standard length	Part number
100 mm	B8-10.0659
500 mm	B8-10.0660
segmented 50 - 95	B8-10.0661



### 31.013.00 H-FLD

### 31.016.00 H-S

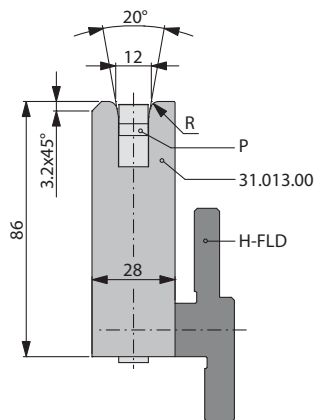

[R] Radius (mm)	3
V - Angle	30-180
[H] Height (mm)	86
[B] Width (mm)	28
Material thickness (mm)	0.7 - 3.0

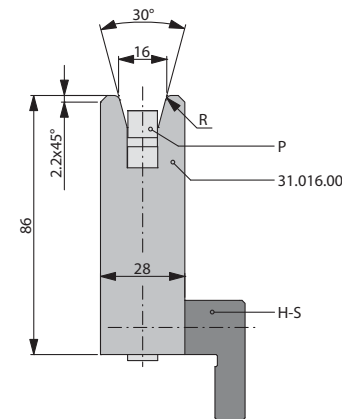

[R] Radius (mm)	2
V - Angle	45-150
[H] Height (mm)	86
[B] Width (mm)	28
Material thickness (mm)	1.5 - 4.0

Standard length	Part number
100 mm	B8-10.0672
500 mm	B8-10.0673
segmented 50 - 95	B8-10.0674

Standard length	Part number
100 mm	B8-10.0685
500 mm	B8-10.0686
segmented 50 - 95	B8-10.0687

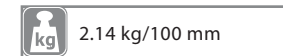
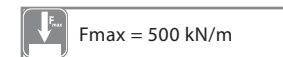
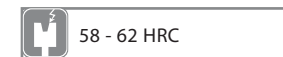
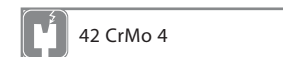
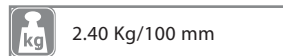
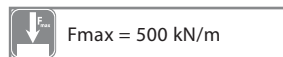
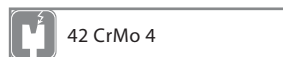

### 31.016.10 H-S

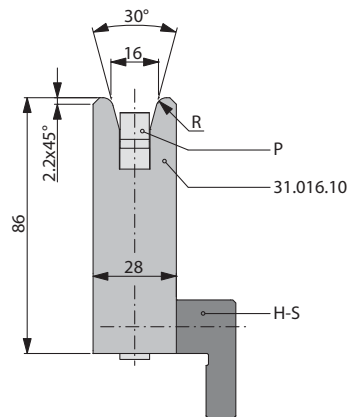
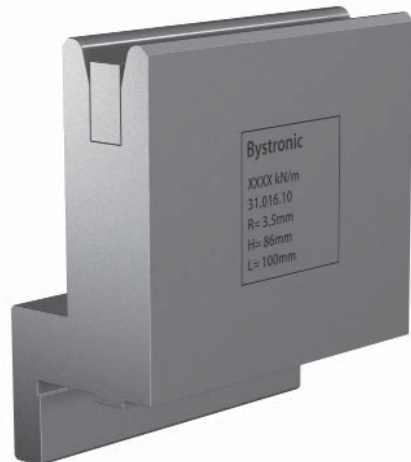

[R] Radius (mm)	3.5
V - Angle	45-150
[H] Height (mm)	86
[B] Width (mm)	28
Material thickness (mm)	1.5 - 4.0

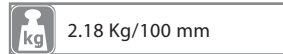
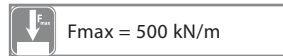
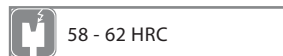
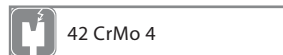

Standard length	Part number
100 mm	B8-10.0698
500 mm	B8-10.0699
segmented 50 - 95	B8-10.0700

### 31.021.00 H-S

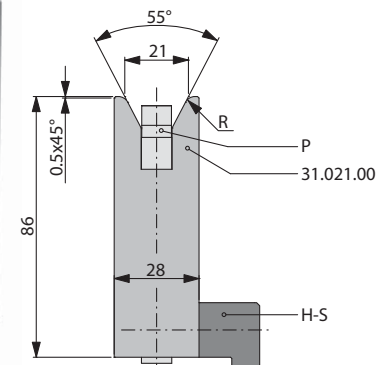

[R] Radius (mm)	3.5
V - Angle	60-160
[H] Height (mm)	86
[B] Width (mm)	28
Material thickness (mm)	2.0 - 4.0

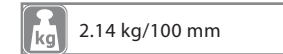
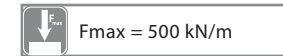
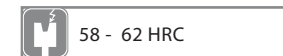
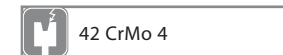

Standard length	Part number
100 mm	B8-10.0724
500 mm	B8-10.0725
segmented 50 - 95	B8-10.0726

### 31.024.00 H-S

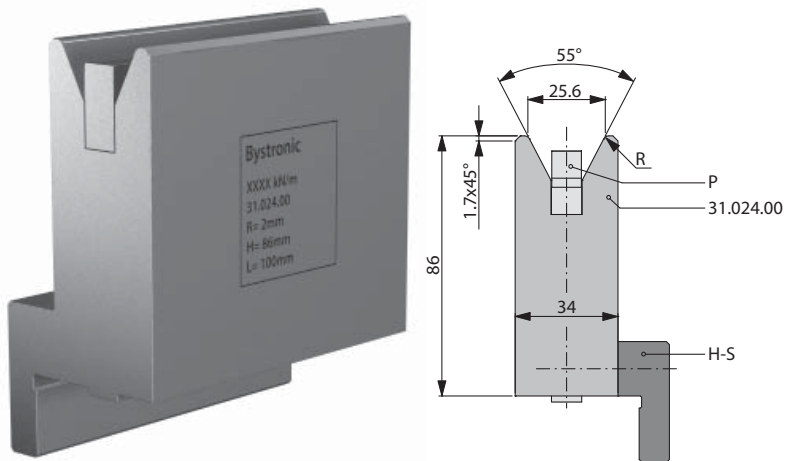

[R] Radius (mm)	2
V - Angle	70-140
[H] Height (mm)	86
[B] Width (mm)	34
Material thickness (mm)	2.0 - 5.0

Standard length	Part number
100 mm	B8-10.0750
500 mm	B8-10.0751
segmented 50 - 95	B8-10.0752

 42 CrMo 4

 58 - 62 HRC

 F<sub>max</sub> = 750 kN/m

 2.44 Kg/100 mm

 Hämmerle 3P

 Ex stock / 24 h

 024.00-04

### 31.032.10 H-S

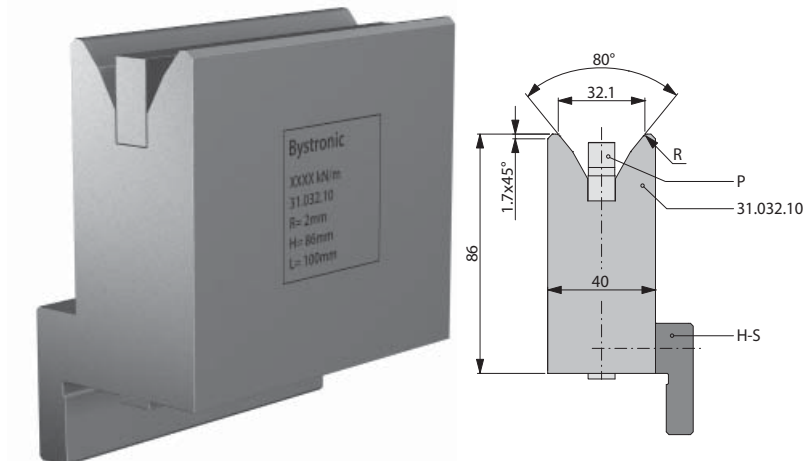



[R] Radius (mm)	2
V - Angle	85-160
[H] Height (mm)	86
[B] Width (mm)	40
Material thickness (mm)	3.5 - 6.0

Standard length	Part number
100 mm	B8-10.0763
500 mm	B8-10.0764
segmented 50 - 95	B8-10.0765

 42 CrMo 4

 58 - 62 HRC

 F<sub>max</sub> = 1200 kN/m

 2.80 kg/100 mm

 Hämmerle 3P

 Ex stock / 24 h

 032.00-06

### 31.040.10 H-S

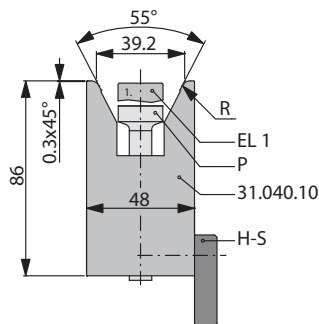

[R] Radius (mm)	4
V - Angle	70-180
[H] Height (mm)	86
[B] Width (mm)	48
Material thickness (mm)	3.5 - 7.0

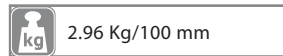
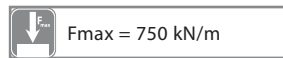
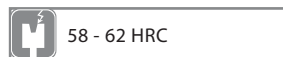

Standard length	Part number
100 mm	B8-10.0776
500 mm	B8-10.0777
segmented 50 - 95	B8-10.0778

### 31.060.00 H-S

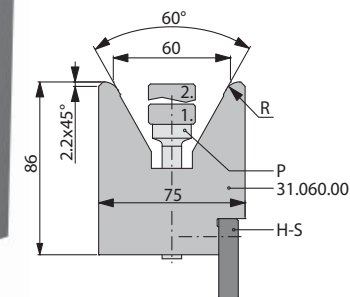

[R] Radius (mm)	8
V - Angle	70-180
[H] Height (mm)	86
[B] Width (mm)	75
Material thickness (mm)	4.0 - 10.0

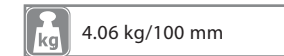
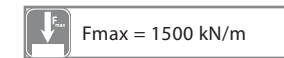
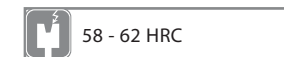
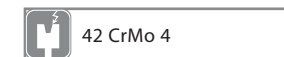

Standard length	Part number
100 mm	B8-10.0802
500 mm	B8-10.0803
segmented 50 - 95	B8-10.0804

### 31.090.00 H-S

### 31.110.00 H-S

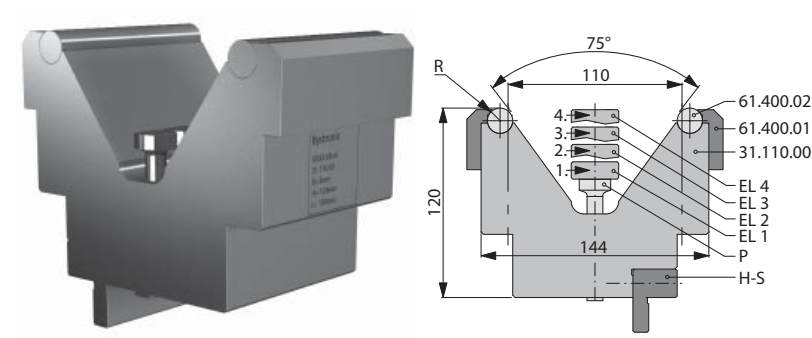
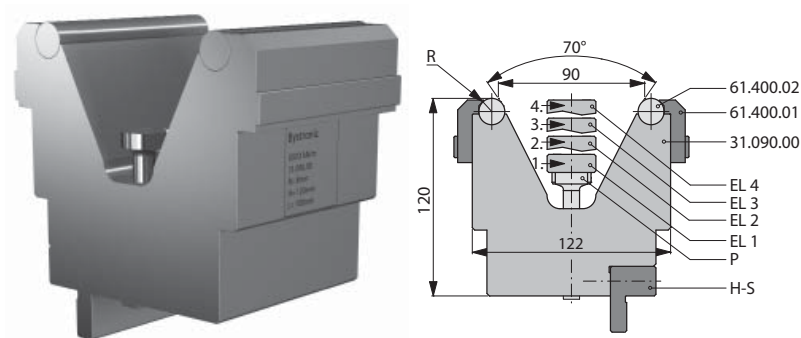

[R] Radius (mm)	8
V - Angle	70-180
[H] Height (mm)	120
[B] Width (mm)	122
Material thickness (mm)	5.0 - 12.0

[R] Radius (mm)	8
V - Angle	75-180
[H] Height (mm)	120
[B] Width (mm)	144
Material thickness (mm)	8.0 - 15.0

42 CrMo 4

42 CrMo 4

58 - 62 HRC

58 - 62 HRC

F<sub>max</sub> = 1500 kN/m

F<sub>max</sub> = 1500 kN/m

8.80 Kg/100 mm

9.48 kg/100 mm

Hämmerle 3P

Hämmerle 3P

Ex stock / 24 h

Ex stock / 24 h

090.00-07

110.00-07

Standard length	Part number
100 mm	B8-10.0841
200 mm	B8-10.0843

Standard length	Part number
100 mm	B8-10.0852
200 mm	B8-10.0854

### Coining bottom tool 41.005.00

### Coining bottom tool 41.007.00

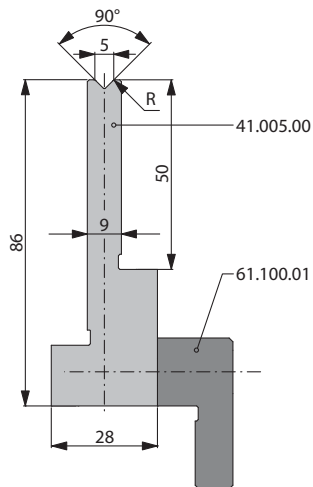

[R] Radius (mm)	1
V - Angle	90
[H] Height (mm)	86
[B] Width (mm)	28
Material thickness (mm)	0.5 - 1.0

Standard length	Part number
100 mm	B8-10.0855
500 mm	B8-10.0856
segmented 50 - 95	

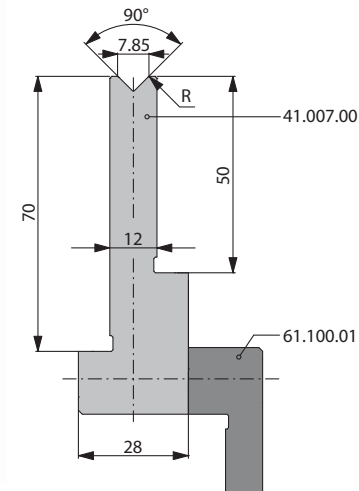
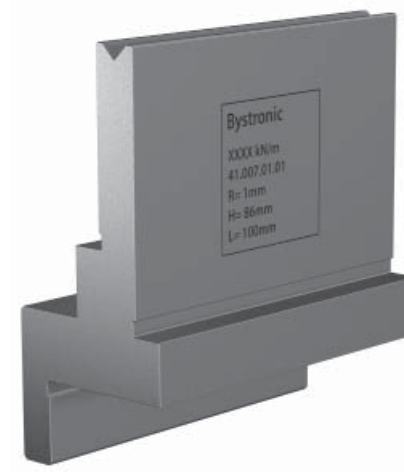
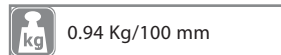
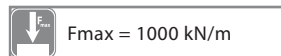
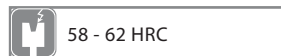
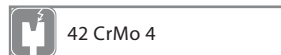

[R] Radius (mm)	1
V - Angle	90
[H] Height (mm)	86
[B] Width (mm)	28
Material thickness (mm)	0.4 - 1.5

Standard length	Part number
100 mm	B8-10.0868
500 mm	B8-10.0869
segmented 50 - 95	B8-10.0870

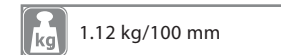
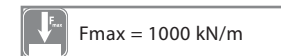
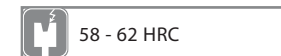
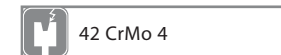

### Coining bottom tool 41.010.00

### Coining bottom tool 41.012.00

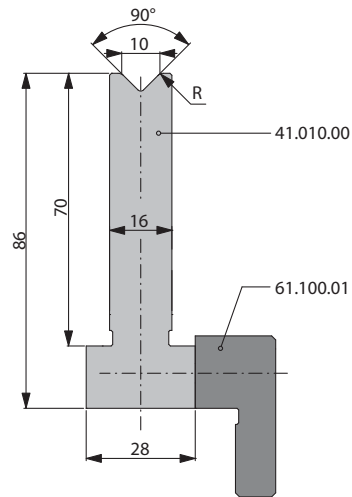
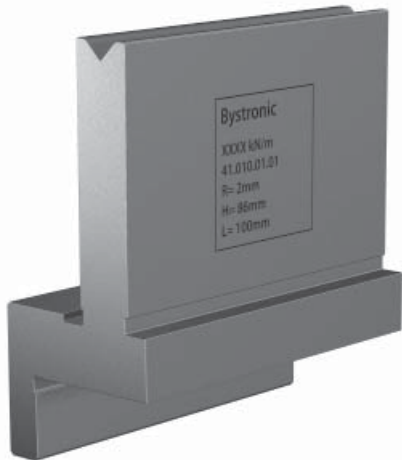

[R] Radius (mm)	2
V - Angle	90
[H] Height (mm)	86
[B] Width (mm)	28
Material thickness (mm)	1.0 - 2.0

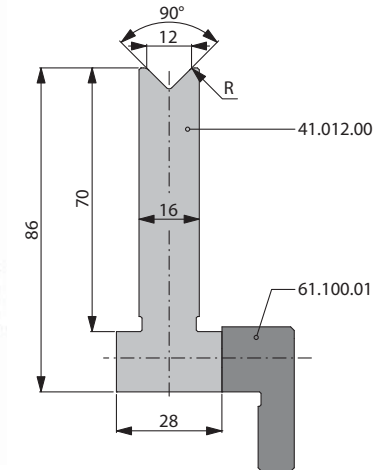
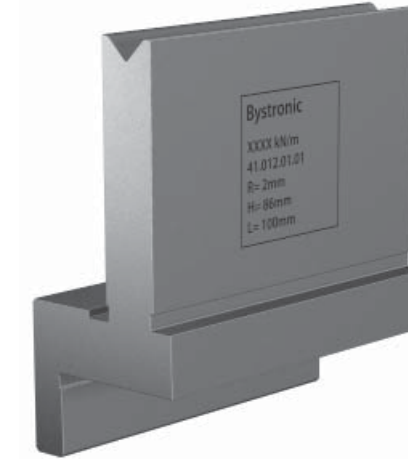

[R] Radius (mm)	2
V - Angle	90
[H] Height (mm)	86
[B] Width (mm)	28
Material thickness (mm)	1.0 - 2.5

Standard length	Part number
100 mm	B8-10.0881
500 mm	B8-10.0882
segmented 50 - 95	B8-10.0883

Standard length	Part number
100 mm	B8-10.0894
500 mm	B8-10.0895
segmented 50 - 95	B8-10.0896

42 CrMo 4

58 - 62 HRC

F<sub>max</sub> = 1000 kN/m

1.22 Kg/100 mm

Hämmerle 3P

Ex stock / 24 h

41.010-01

42 CrMo 4

58 - 62 HRC

F<sub>max</sub> = 1000 kN/m

1.20 kg/100 mm

Hämmerle 3P

Ex stock / 24 h

41.012-01

Bottom tool pin

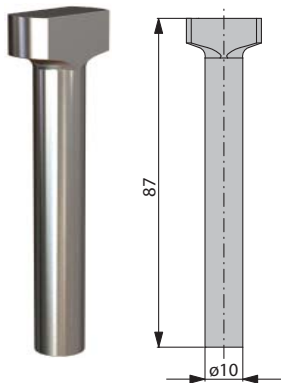

61.200.21

Part number	Size (mm)	Weight (Kg)
.01	20 x 87	0,06
.02	15 x 87	0,05

61.200.21.01

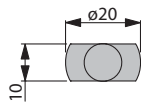

61.200.21.02

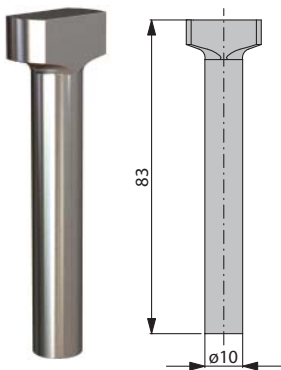
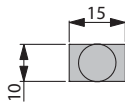

61.200.22

Part number	Size (mm)	Weight (Kg)
.01	20 x 83	0,06
.02	15 x 83	0,05

61.200.22.01

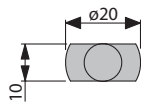

61.200.22.02

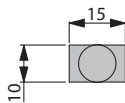

Bottom tool pin

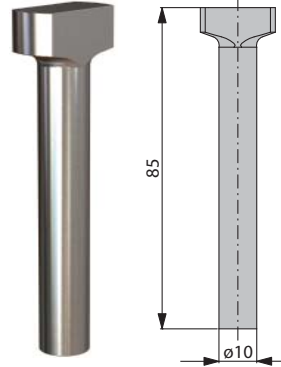

61.200.23

Part number	Size (mm)	Weight (Kg)
.01	20 x 85	0,06
.02	15 x 85	0,05

61.200.23.01

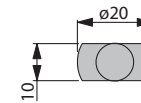

61.200.23.02

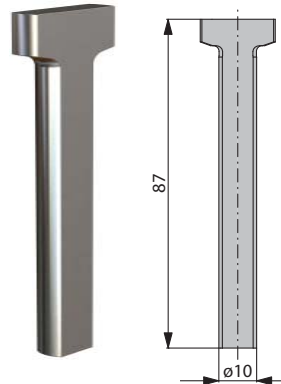
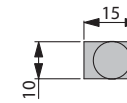

61.200.24

Part number	Size (mm)	Weight (Kg)
.01	20 x 87	0,06
.02	15 x 87	0,05

61.200.24.01

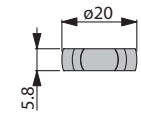

61.200.24.02

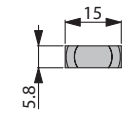



Bottom tool pin

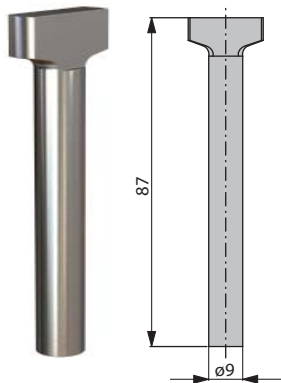

61.200.25

Part number	Size (mm)	Weight (Kg)
.01	20 x 87	0,06
.02	15 x 87	0,05

61.200.25.01

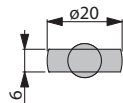

61.200.25.02

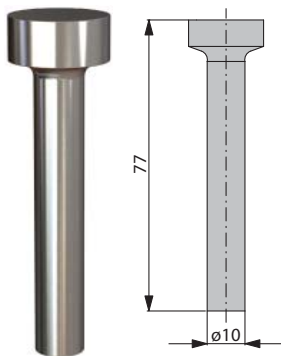
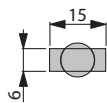

61.200.26

Part number	Size (mm)	Weight (Kg)
.01	20 x 87	0,06
.02	15 x 87	0,05

61.200.26.01

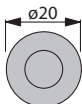

61.200.26.02



Bottom tool pin

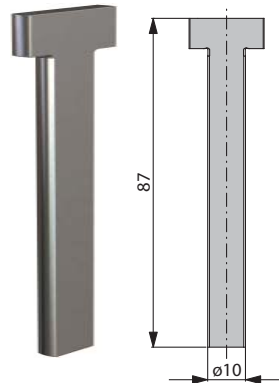

61.200.27

Part number	Size (mm)	Weight (Kg)
.01	20 x 87	0,02
.02	15 x 87	0,01

61.200.27.01

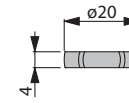

61.200.27.02

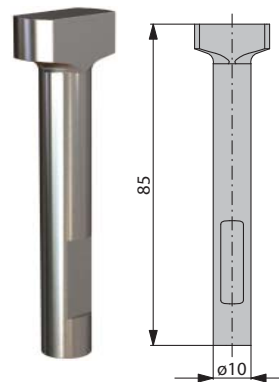
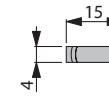

61.200.28

Part number	Size (mm)	Weight (Kg)
.01	20 x 85	0,06
.02	15 x 85	0,05

61.200.28.01

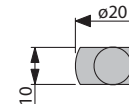

61.200.28.02

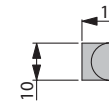

Bottom tool pin

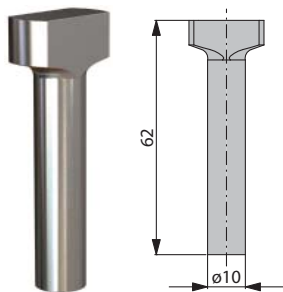

61.200.29

Part number	Size (mm)	Weight (Kg)
.01	20 x 62	0,06
.02	15 x 62	0,05

61.200.29.01

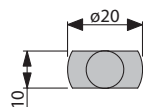

61.200.29.02

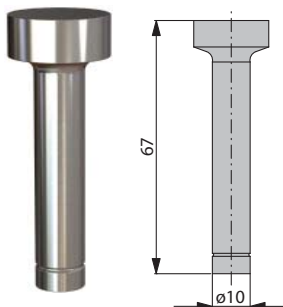
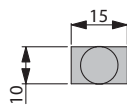

61.200.30

Part number	Size (mm)	Weight (Kg)
.01	20 x 67	0,06
.02	15 x 67	0,05

61.200.30.01

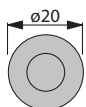

61.200.30.02



Bottom tool pin

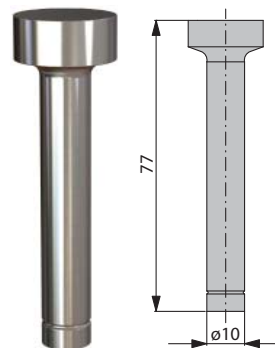

61.200.31

Part number	Size (mm)	Weight (Kg)
.01	20 x 77	0,06
.02	15 x 77	0,05

61.200.31.01

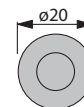

61.200.31.02



## Insert rails

Who will need insert rails?

To provide maximum flexibility in the range of angle that can be formed using lower tools from 31.040.10 (V40) and larger, insert rails are available.

Details of the various insert rails available are provided on the following pages.

(All insert rails are manufactured from CK45 steel and have a hardness of 58 - 60 HRC.)



## Insert rails

Insert rail 61.500.01

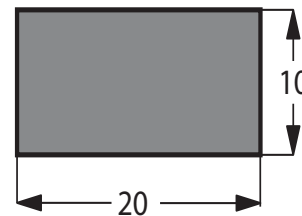

Part number	Length (mm)	Size (mm)	Weight (kg)
B8-61.500.01.01	100	20 x 10	0,16
B8-61.500.01.02	50	20 x 10	0,08
B8-61.500.01.03	55	20 x 10	0,088
B8-61.500.01.04	60	20 x 10	0,096
B8-61.500.01.05	65	20 x 10	0,104
B8-61.500.01.06	70	20 x 10	0,112
B8-61.500.01.07	75	20 x 10	0,120
B8-61.500.01.08	80	20 x 10	0,128
B8-61.500.01.09	85	20 x 10	1,136
B8-61.500.01.10	90	20 x 10	0,144
B8-61.500.01.11	95	20 x 10	0,152
B8-61.500.01.12	500	20 x 10	0,8

## Insert rails

262

Insert rail 61.500.04

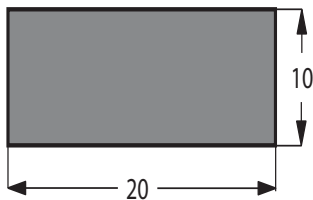

Part number	Length (mm)	Size (mm)	Weight (kg)
B8-61.500.04.01	100	30 x 11	0,26
B8-61.500.04.02	50	30 x 11	0,13
B8-61.500.04.03	55	30 x 11	0,143
B8-61.500.04.04	60	30 x 11	0,156
B8-61.500.04.05	65	30 x 11	0,169
B8-61.500.04.06	70	30 x 11	0,182
B8-61.500.04.07	75	30 x 11	0,195
B8-61.500.04.08	80	30 x 11	0,208
B8-61.500.04.09	85	30 x 11	0,221
B8-61.500.04.10	90	30 x 11	0,234
B8-61.500.04.11	95	30 x 11	0,247
B8-61.500.04.12	500	30 x 11	1,3

## Insert rails

263

Insert rail 61.500.05

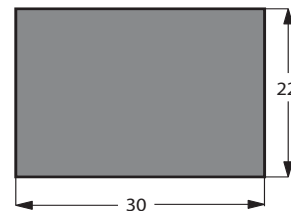

Part number	Length (mm)	Size (mm)	Weight (kg)
B8-61.500.05.01	100	20 x 10	0,5
B8-61.500.05.02	50	20 x 10	0,25
B8-61.500.05.03	55	20 x 10	0,275
B8-61.500.05.04	60	20 x 10	0,3
B8-61.500.05.05	65	20 x 10	0,325
B8-61.500.05.06	70	20 x 10	0,35
B8-61.500.05.07	75	20 x 10	0,375
B8-61.500.05.08	80	20 x 10	0,4
B8-61.500.05.09	85	20 x 10	0,425
B8-61.500.05.10	90	20 x 10	0,45
B8-61.500.05.11	95	20 x 10	0,475
B8-61.500.05.12	500	20 x 10	2,5

## Insert rails

264

Insert rail 61.500.04

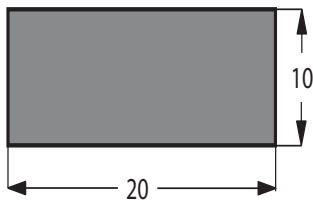

Part number	Length (mm)	Size (mm)	Weight (kg)
B8-61.500.04.01	100	30 x 11	0,26
B8-61.500.04.02	50	30 x 11	0,13
B8-61.500.04.03	55	30 x 11	0,143
B8-61.500.04.04	60	30 x 11	0,156
B8-61.500.04.05	65	30 x 11	0,169
B8-61.500.04.06	70	30 x 11	0,182
B8-61.500.04.07	75	30 x 11	0,195
B8-61.500.04.08	80	30 x 11	0,208
B8-61.500.04.09	85	30 x 11	0,221
B8-61.500.04.10	90	30 x 11	0,234
B8-61.500.04.11	95	30 x 11	0,247
B8-61.500.04.12	500	30 x 11	1,3

## Insert rails

265

Insert rail 61.500.05

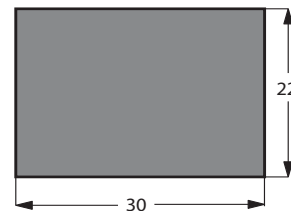

Part number	Length (mm)	Size (mm)	Weight (kg)
B8-61.500.05.01	100	20 x 10	0,5
B8-61.500.05.02	50	20 x 10	0,25
B8-61.500.05.03	55	20 x 10	0,275
B8-61.500.05.04	60	20 x 10	0,3
B8-61.500.05.05	65	20 x 10	0,325
B8-61.500.05.06	70	20 x 10	0,35
B8-61.500.05.07	75	20 x 10	0,375
B8-61.500.05.08	80	20 x 10	0,4
B8-61.500.05.09	85	20 x 10	0,425
B8-61.500.05.10	90	20 x 10	0,45
B8-61.500.05.11	95	20 x 10	0,475
B8-61.500.05.12	500	20 x 10	2,5

## Insert rails

266

Insert rail 61.500.06

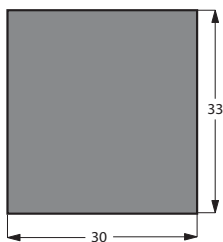

Part number	Length (mm)	Size (mm)	Weight (kg)
B8-61.500.06.01	100	30 x 33	0,78
B8-61.500.06.02	50	30 x 33	0,39
B8-61.500.06.03	55	30 x 33	0,429
B8-61.500.06.04	60	30 x 33	0,468
B8-61.500.06.05	65	30 x 33	0,507
B8-61.500.06.06	70	30 x 33	0,546
B8-61.500.06.07	75	30 x 33	0,585
B8-61.500.06.08	80	30 x 33	0,624
B8-61.500.06.09	85	30 x 33	0,663
B8-61.500.06.10	90	30 x 33	0,702
B8-61.500.06.11	95	30 x 33	0,741
B8-61.500.06.12	500	30 x 33	3,9

## Insert rails

267

Insert rail 61.500.07

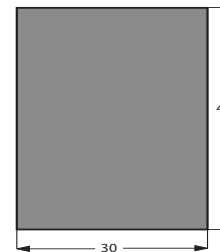

Part number	Length (mm)	Size (mm)	Weight (kg)
B8-61.500.07.01	100	33 x 44	1,04
B8-61.500.07.02	50	33 x 44	0,52
B8-61.500.07.03	55	33 x 44	0,572
B8-61.500.07.04	60	33 x 44	0,624
B8-61.500.07.05	65	33 x 44	0,676
B8-61.500.07.06	70	33 x 44	0,728
B8-61.500.07.07	75	33 x 44	0,78
B8-61.500.07.08	80	33 x 44	0,832
B8-61.500.07.09	85	33 x 44	0,884
B8-61.500.07.10	90	33 x 44	0,936
B8-61.500.07.11	95	33 x 44	0,988
B8-61.500.07.12	500	33 x 44	5,2

## Contacts

### Bystronic do Brasil Ltda.

Rue Arapongas, 285  
83.040-200  
Sao José dos Pinhais Paraná  
**Brazil**

Tel. +55 41 3398 2000  
Fax +55 41 3398 1789

### Bystronic Canada Ltd.

5730 Coopers Avenue #24  
L4Z 2E9 Mississauga  
**Canada**

Tel. +1 905 890 2999  
Fax +1 905 890 2998

### Bystronic Czech Republic s.r.o.

Turanka 115/1222  
PSC 627 00 Brno  
**Ceská Republika**  
Tel. +420 532 123 314  
Fax +420 532 123 315

### Bystronic Co., Ltd (Shanghai)

RiJing Road 88, WaiGaoQiao  
FTZ PuDong, Shanghai  
**China** 200131

Tel. +86 21 586 80 480  
Fax +86 21 568 80 481

### Bystronic DK

Ådalsvej 4  
DK-4100 Ringsted  
**Danmark**

Tel. +45 56 87 91 00  
Fax +45 56 87 91 10

### Bystronic Deutschland GmbH

Römerstraße 14  
71296 Heimsheim  
**Deutschland**  
Tel. +49 7033 4699 0  
Fax +49 7033 4699 222

### Bystronic Iberica, S.A.

Avenida Tenerife  
2 Edificio Marpe I, 3a planta  
ES-28700 San Sebastián de los  
Reyes (Madrid)

**Espania**  
Tel. +34 91 654 48 78  
Fax +34 91 652 49 83

### Bystronic France S.A.

Park Technopolis  
3 Avenue du Canada  
F-91940 Les Ulis

**France**  
Tel. +33 1 69 41 99 84  
Fax +33 1 69 41 99 51

### Bystronic Laser India (Pvt) Ltd.

7 C, Tadiwala Road  
Next to Hotel Panchratna  
Pune 411 001

**India**  
Tel. +91 20 67294800  
Mobile +91 9922000542

### Bystronic Italia SRL

Via del Lavoro 30  
I-20813 Bovisio Masciago (MB)

**Italia**  
Tel. +39 0362 59 93 1  
Fax +39 0362 59 93 209

### Bystronic Korea, B/D

1027-11 Hogye-Dong,  
Dongan-Gu, Anyang-Si,  
Gyeonggi-Do

**Korea**  
Tel. +82 31 389 9800  
Fax +82 31 389 9819

### Bystronic Mexico S.A. de C.V.

Calle Canes 3250 Int.23,  
Col. La Nogalera  
44470 Guadalajara, Jalisco

**Mexico**  
Tel. +52 33 3044 0505  
Fax +52 33 1380 9979

### Bystronic Benelux BV

Stek 8  
NL-3371 KG Hardinxveld-  
Giessendam

**Nederland**  
Tel. +31 184 611 020  
Fax +31 184 617 774

### Bystronic Austria GmbH

Salzburger Straße 205  
AT-4030 Linz

**Österreich**  
Tel. +43 732 341 155  
Fax +43 732 341 153

### Bystronic Polska Sp. z o.o.

Al. Krakowska 38, Janki  
PL-05-090 Raszyn

**Polska**  
Tel. +48 22 331 377 0  
Fax +48 22 331 377 1

### OOO Bystronic Laser

Berzarina Street, 12  
123298 Moscow

**Russia**  
Tel. +7 495 276 15 16  
Fax +7 495 276 15 17

### Bystronic Sales AG

Industriestrasse 21  
CH-3362 Niederönz

**Schweiz**  
Tel. +41 62 956 37 38  
Fax +41 62 956 33 81

### Bystronic PTE LTD

2 Leng Kee Road #03-05  
Thye Hong Centre  
**Singapore** 159086

Tel. +65 6472 6300  
Fax +65 6472 6032

### Bystronic Scandinavia AB

Metallvägen 30 A  
SE-195 72 Rosersberg

**Sverige**  
Tel. +46 8 594 415 50  
Fax +46 8 594 415 55

### Bystronic Lazer

Kozyatagi Ilknur Keles Sok.  
8 Tema Plaza  
34742 Kadikoy – Istanbul

**Turkey**  
Tel.: +90 216 464 61 60  
Fax: +90 216 464 61 11

### Bystronic UK Limited

6 Wayside Business Park  
Wilson Lane  
Coventry CV6 6NY

**United Kingdom**  
Tel. +44 844 848 5850  
Fax +44 844 848 5851

### Bystronic Inc.

185 Commerce Drive  
Hauppauge, NY 11788

**USA**  
Tel. +1 631 231 1212  
Fax +1 631 231 1040



## Notizen

270

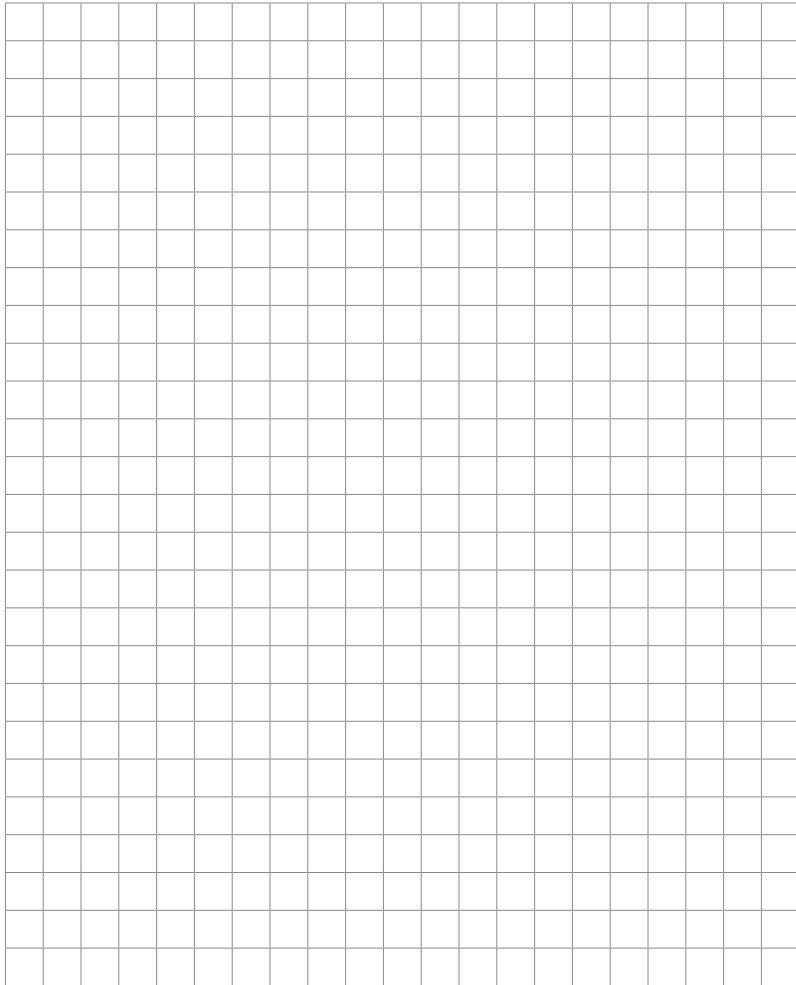

## Notizen

271

